

# MINIMAL ALMOST CONVEXITY

MURRAY ELDER AND SUSAN HERMILLER<sup>1</sup>

ABSTRACT. In this article we show that the Baumslag-Solitar group  $BS(1, 2)$  is minimally almost convex, or  $MAC$ . We also show that  $BS(1, 2)$  does not satisfy Poénaru's almost convexity condition  $P(2)$ , and hence the condition  $P(2)$  is strictly stronger than  $MAC$ . Finally, we show that the groups  $BS(1, q)$  for  $q \geq 7$  and Stallings' non- $FP_3$  group do not satisfy  $MAC$ . As a consequence, the condition  $MAC$  is not a commensurability invariant.

## 1. INTRODUCTION

Let  $G$  be a group with finite generating set  $A$ , let  $\Gamma$  be the corresponding Cayley graph with the path metric  $d$ , and let  $S(r)$  and  $B(r)$  denote the sphere and ball, respectively, of radius  $r$  in  $\Gamma$ . The pair  $(G, A)$  satisfies the almost convexity condition  $AC_{f,r_0}$  for a function  $f : \mathbb{N} \rightarrow \mathbb{R}_+$  and a natural number  $r_0 \in \mathbb{N}$  if for every natural number  $r \geq r_0$  and every pair of vertices  $a, b \in S(r)$  with  $d(a, b) \leq 2$ , there is a path inside  $B(r)$  from  $a$  to  $b$  of length at most  $f(r)$ . Note that every group satisfies the condition  $AC_{f,1}$  for the function  $f(r) = 2r$ . A group is *minimally almost convex*, or  $MAC$  (called  $K(2)$  in [10]), if the condition  $AC_{f,r_0}$  holds for the function  $f(r) = 2r - 1$  and some number  $r_0$ ; that is, the least restriction possible is imposed on the function  $f$ . If the next least minimal restriction is imposed, i.e. if  $G$  is  $AC_{f,r_0}$  with the function  $f(r) = 2r - 2$ , then the group is said to be  $M'AC$  ( $K'(2)$  in [10]). Increasing the restriction on the function  $f$  further, the group satisfies Poénaru's  $P(2)$  condition [7, 13] if  $AC_{f,r_0}$  holds for a sublinear function  $f : \mathbb{N} \rightarrow \mathbb{R}_+$ , i.e.  $f$  satisfies the property that for every number  $C > 0$  the limit  $\lim_{r \rightarrow \infty} (r - Cf(r)) = \infty$ . All of these definitions are generalizations of the original concept of almost convexity given by Cannon in [3], in which the greatest restriction is placed on the function  $f$ , namely that a group is *almost convex* or  $AC$  if there is a constant function  $f(r) \equiv C$  for which the group satisfies the condition  $AC_{C,1}$ . Results of [3, 10, 14] show that the condition  $MAC$ , and hence each of the other almost convexity conditions, implies finite presentation of the group and solvability of the word problem.

---

*Date:* June 15, 2007.

*2000 Mathematics Subject Classification.* 20F65.

*Key words and phrases.* (Minimally) almost convex, Baumslag-Solitar group, Stallings group.

<sup>1</sup>Supported under NSF grant no. DMS-0071037

The successive strengthenings of the restrictions in the definitions above give the implications  $AC \Rightarrow P(2) \Rightarrow M'AC \Rightarrow MAC$ . For this series of implications, a natural question to ask is, which of the implications can be reversed? A natural family of groups to consider are the Baumslag-Solitar groups  $BS(1, q) := \langle a, t \mid tat^{-1} = a^q \rangle$  with  $|q| > 1$ , which Miller and Shapiro [12] proved are not almost convex with respect to any generating set.

In the present paper, the structure of geodesics in the Cayley graph of  $BS(1, q)$  is analyzed in greater detail, in Section 2. In Section 3, we use these results to show that the group  $BS(1, 2)$  satisfies the property  $M'AC$ . In Section 4 we show that the group  $BS(1, 2)$  does not satisfy the  $P(2)$  condition, and hence the implication  $P(2) \Rightarrow M'AC$  cannot be reversed.

In section 4 we also show that the groups  $BS(1, q) = \langle a, t \mid tat^{-1} = a^q \rangle$  for  $q \geq 7$  are not  $MAC$ . Since the group  $BS(1, 8)$  is a finite index subgroup of  $BS(1, 2)$ , an immediate consequence of this result is that both  $MAC$  and  $M'AC$  are not commensurability invariants, and hence not quasi-isometry invariants. The related property  $AC$  is also known to vary under quasi-isometry; in particular, Thiel [16] has shown that  $AC$  depends on the generating set.

Finally, in Section 5 we consider Stallings' non- $FP_3$  group [15], which was shown by the first author [4, 5] not to be almost convex with respect to two different finite generating sets. In Theorem 5.3, we prove the stronger result that this group also is not  $MAC$ , with respect to one of the generating sets. Combining this with a result of Bridson [2] that this group has a quadratic isoperimetric function, we obtain an example of a group with quadratic isoperimetric function that is not  $MAC$ . During the writing of this paper, Belk and Bux [1] have shown another such example; namely, they have shown that Thomson's group  $F$ , which also has a quadratic isoperimetric function [9], does not satisfy  $MAC$ .

## 2. BACKGROUND ON BAUMSLAG-SOLITAR GROUPS

Let  $G := BS(1, q) = \langle a, t \mid tat^{-1} = a^q \rangle$  with generators  $A := \{a, a^{-1}, t, t^{-1}\}$  for any natural number  $q > 1$ . Let  $\Gamma$  denote the corresponding Cayley graph with path metric  $d$ , and let  $\mathcal{C}$  denote the corresponding Cayley 2-complex.

The complex  $\mathcal{C}$  can be built from "bricks" homeomorphic to  $[0, 1] \times [0, 1]$ , with both vertical sides labeled by a "t" upward, the top horizontal side labeled by an "a" to the right, and the bottom horizontal side split into  $q$  edges each labeled by an "a" to the right. These bricks can be stacked horizontally into "strips". For each strip,  $q$  other strips can be attached at the top, and one on the bottom. For any set of successive choices upward, then, the strips of bricks can be stacked vertically to fill the plane. The Cayley complex then is homeomorphic to the Cartesian product of the real line with a regular tree  $T$  of valence  $q + 1$ ; see Figure 1. Let  $\pi : \mathcal{C} \rightarrow T$  be the horizontal projection map. For an edge  $e$  of  $T$ ,  $e$  inherits an upward

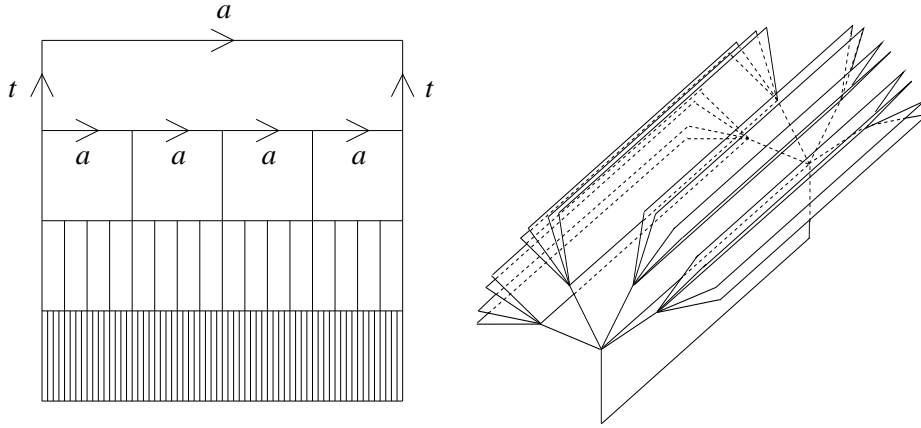

FIGURE 1. A brick in a plane, and a side-on view of the Cayley graph  $\Gamma$  for  $BS(1, 4)$ .

direction from the upward labels on the vertical edges of  $\mathcal{C}$  that project onto  $e$ . More details can be found in [6] (pages 154-160).

For any word  $w \in A^*$ , let  $\bar{w}$  denote the image of  $w$  in  $BS(1, q)$ . For words  $v, w \in A^*$ , denote  $v = w$  if  $v$  and  $w$  are the same words in  $A^*$ , and  $v =_G w$  if  $\bar{v} = \bar{w}$ . Let  $l(w)$  denote the word length of  $w$  and let  $w(i)$  denote the prefix of the word  $w$  containing  $i$  letters. Then  $(w^{-1}(i))^{-1}$  is the suffix of  $w$  of length  $i$ . Define  $\sigma_t(v)$  to be the exponent sum of all occurrences of  $t$  and  $t^{-1}$  in  $v$ . Note that relator  $tat^{-1}a^{-q}$  in the presentation of  $G$  satisfies  $\sigma_t(tat^{-1}a^{-q}) = 0$ ; hence whenever  $v =_G w$ , then  $\sigma_t(v) = \sigma_t(w)$ .

The following Lemma is well-known; a proof can be found in [11].

**Lemma 2.1** (Commutation). *If  $v, w \in A^*$  and  $\sigma_t(v) = 0 = \sigma_t(w)$ , then  $vw =_G wv$ .*

Let  $E$  denote the set of words in  $\{a, a^{-1}\}^*$ ,  $P$  the words in  $\{a, a^{-1}, t\}^*$  containing at least one  $t$  letter, and  $N$  the words in  $\{a, a^{-1}, t^{-1}\}^*$  containing at least one  $t^{-1}$  letter. A word  $w = w_1w_2$  with  $w_1 \in N$  and  $w_2 \in P$ , then, will be referred to as a word in  $NP$ . Finally, let  $X$  denote the subset of the words in  $PN$  with  $t$ -exponent sum equal to 0. Letters in parentheses denote subwords that may or may not be present; for example,  $P(X) := P \cup PX$ . The following statement is proved in [8].

**Lemma 2.2** (Classes of geodesics). *A word  $w \in A^*$  that is a geodesic in  $\Gamma$  must fall into one of four classes:*

- (1)  $E$  or  $X$ ,
- (2)  $N$  or  $XN$ ,
- (3)  $P$  or  $PX$ ,
- (4)  $NP$ , or  $NPX$  with  $\sigma_t(w) \geq 0$ , or  $XNP$  with  $\sigma_t(w) \leq 0$ .

Analyzing the geodesics more carefully, we find a normal form for geodesics in the following Proposition.

**Proposition 2.3** (Normal form). *If  $w \in A^*$  is a geodesic in  $G = BS(1, q)$ , then there is another geodesic  $\hat{w} \in A^*$  with  $\overline{\hat{w}} = \overline{w}$  such that for  $w$  in each class,  $\hat{w}$  has the following form (respectively):*

- (1)  $\hat{w} = a^i$  for  $|i| \leq C_q$  where  $C_q := \lfloor \frac{q}{2} + 1 \rfloor$  if  $q > 2$  and  $C_2 := 3$ , or  $\hat{w} = w_0 \in X$ ,
- (2)  $\hat{w} = w_0 t^{-1} a^{m_1} \dots t^{-1} a^{m_e}$  with  $|m_j| \leq \lfloor \frac{q}{2} \rfloor$  for all  $j$ ,  $e \geq 1$ , and either  $w_0 = a^i$  for  $|i| \leq C_q$  or  $w_0 \in X$ ,
- (3)  $\hat{w} = a^{n_0} t \dots a^{n_{f-1}} t w_0$  with  $|n_j| \leq \lfloor \frac{q}{2} \rfloor$  for all  $j$ ,  $f \geq 1$ , and either  $w_0 = a^i$  for  $|i| \leq C_q$  or  $w_0 \in X$ ,
- (4) Either  $\hat{w} = t^{-e} a^{m_f} t a^{m_{f-1}} \dots a^{m_1} t w_0$  with  $1 \leq e \leq f$ , or  $\hat{w} = w_0 t^{-1} a^{m_1} \dots t^{-1} a^{m_e} t^f$  with  $1 \leq f \leq e$ , such that  $|m_j| \leq \lfloor \frac{q}{2} \rfloor$  for all  $j$ , and either  $w_0 = a^i$  for  $|i| \leq C_q$  or  $w_0 \in X$ . Note that if  $\sigma_t(w) = 0$  then  $e = f$  and either expression is valid.

In every class the word  $w_0 \in X$  can be chosen to be either of the form  $w_0 = t^h a^s t^{-1} a^{k_{h-1}} \dots a^{k_1} t^{-1} a^{k_0}$  or  $w_0 = a^{k_0} t a^{k_1} \dots t a^{k_{h-1}} t a^s t^{-h}$  with  $|k_j| \leq \lfloor \frac{q}{2} \rfloor$  for all  $j$ ,  $1 \leq |s| \leq q-1$  if  $q > 2$ ,  $2 \leq |s| \leq 3$  if  $q = 2$ , and  $h \geq 1$ .

*Proof.* Note that the natural number  $q = \lfloor \frac{q}{2} + 1 \rfloor + \lceil \frac{q}{2} - 1 \rceil$ .

For a geodesic  $w$  in class (1), if  $w \in E$ , then  $w = a^i$  for some  $i$ . If  $q = 2$ , then  $a^{\pm 6} = ta^{\pm 3}t^{-1}$  so  $|i| \leq 6$ , and the words  $a^{\pm(4+k)}$  have normal form  $ta^{\pm 2}t^{-1}a^{\pm k} \in X$  for  $k = 0$  and  $k = 1$ . If  $q > 2$ , then the relation  $tat^{-1} =_G a^q$  can be reformulated as  $a^{\pm \lfloor \frac{q}{2} + 1 \rfloor + 1} =_G ta^{\pm 1}t^{-1}a^{\mp(\lceil \frac{q}{2} - 1 \rceil - 1)}$ . If  $q$  is even, then  $a^{\pm \frac{q}{2} + 2}$  is not geodesic, so  $|i| \leq \lfloor \frac{q}{2} + 1 \rfloor$ . On the other hand, if  $q$  is odd, then  $a^{\pm \frac{q+1}{2} + 2} =_G ta^{\pm 1}t^{-1}a^{\mp(\frac{q-1}{2} - 2)}$  so  $a^{\pm \frac{q+1}{2} + 2}$  is not geodesic; hence  $|i| \leq \lfloor \frac{q}{2} + 1 \rfloor + 1$ , and the words  $a^{\pm \lfloor \frac{q}{2} + 1 \rfloor + 1}$  have a normal form in  $X$ .

Next suppose that  $w$  is a geodesic in class (2). Then  $w \in (X)N$ , so  $w = w'_0 t^{-1} a^{l_1} t^{-1} a^{l_2} \dots t^{-1} a^{l_e}$  for some word  $w'_0$  in class (1),  $e \geq 1$ , and integers  $l_i$ . Again we reformulate the defining relation of  $G$ , in this case to  $t^{-1} a^{\pm \lfloor \frac{q}{2} + 1 \rfloor} =_G a^{\pm 1} t^{-1} a^{\mp(\lceil \frac{q}{2} - 1 \rceil)}$ . If  $q$  is odd, then we may (repeatedly) replace any occurrence of  $t^{-1} a^{\pm \lfloor \frac{q}{2} + 1 \rfloor}$  by  $a^{\pm 1} t^{-1} a^{\mp(\lceil \frac{q}{2} - 1 \rceil)}$ . If  $q$  is even,  $t^{-1} a^{\pm \lfloor \frac{q}{2} + 1 \rfloor}$  is not geodesic, so  $|l_j| \leq \lfloor \frac{q}{2} \rfloor$  for all  $j$  and replacements are not needed. In both cases, then, we obtain a geodesic word of the form  $w''_0 t^{-1} a^{m_1} t^{-1} a^{m_2} \dots t^{-1} a^{m_e}$  with each  $|m_j| \leq \lfloor \frac{q}{2} \rfloor$  and  $w''_0$  in class (1); to form the normal form  $\hat{w}$ , then, replace  $w''_0$  by its normal form.

The proof of the normal form for geodesics in class (3) is very similar, using the relation  $a^{\pm \lfloor \frac{q}{2} + 1 \rfloor} t =_G a^{\mp(\lceil \frac{q}{2} - 1 \rceil)} t a^{\pm 1}$ .

Suppose next that  $w$  is a geodesic in class (4) with  $\sigma_t(w) \geq 0$ . Then  $w = t^{-1} a^{k_1} \dots a^{k_{e-1}} t^{-1} a^{l_f} t a^{l_{f-1}} \dots a^{l_1} t w'_0$  with  $w'_0$  in class (1),  $1 \leq e < f$ , and each  $k_j, l_i \in \mathbb{Z}$ . First use Lemma 2.1 to replace  $w$  by the geodesic word

$$t^{-e} a^{l_f} t a^{k_{e-1} + l_{f-1}} \dots t a^{k_1 + l_f - e + 1} t a^{l_f - e} \tilde{w}_0 t a^{l_f - e - 1} \dots a^{l_1} t w'_0.$$

To complete construction of the normal form  $\hat{w}$  from this word, replace the subword  $a^{l_f} t \dots a^{l_1} t w'_0$  by its normal form from class (3).

The constructions for the normal forms of geodesics  $w$  in class (4) with  $\sigma_t(w) \leq 0$ , and of geodesics  $w_0 \in X$ , are analogous.  $\square$

### 3. THE GROUP $BS(1,2)$ SATISFIES $M'AC$

Let  $G := BS(1,2) = \langle a, t \mid tat^{-1} = a^2 \rangle$  with generators  $A := \{a, a^{-1}, t, t^{-1}\}$ . In this section we prove, in Theorem 3.5, that this group is  $M'AC$ . We begin with a further analysis of the geodesics in  $G$ , via several lemmas which are utilized in many of the cases in the proof of Theorem 3.5.

**Lemma 3.1** (Large geodesic). *If  $w$  is a geodesic of length  $r > 200$  in one of the classes (1), (2), or (3) of Proposition 2.3 and  $|\sigma_t(w)| \leq 2$ , then  $w$  is in either  $X$ ,  $XN$ , or  $PX$ , respectively. Moreover, the  $X$  subword of  $w$  must have the form  $w_1w_2$  with  $w_1 \in P$  and  $w_2 \in N$  such that  $\sigma_t(w_1) = -\sigma_t(w_2) > 10$ .*

*Proof.* Suppose that  $w$  is a geodesic in either  $E$ ,  $N$ , or  $P$  of length  $r > 200$ , and  $|\sigma_t(w)| \leq 2$ . Then  $w$  contains at most two occurrences of the letters  $t$  and  $t^{-1}$ . As mentioned in the proof of Proposition 2.3,  $a^{\pm 6} = ta^{\pm 3}t^{-1}$  so  $a^j$  is not geodesic for  $|j| \geq 6$ . Hence  $w$  contains at most 15 occurrences of the letters  $a$  and  $a^{-1}$  interspersed among the  $t^{\pm 1}$  letters. Then  $l(w) \leq 17$ , giving a contradiction.  $\square$

Given a word  $w_0 \in X$ , there is a natural number  $k \in \mathbb{N}$  with  $w_0 =_G a^k$ ; denote  $\tilde{w}_0 := a^k$ . If  $w$  is a geodesic word in  $E \cup N \cup P \cup NP$ , then let  $\tilde{w} := w$ . Combining these, for any geodesic word  $w = w_0w_1$  (or  $w = w_1w_0$ ) with  $w_0 \in X$  and  $w_1 \in N \cup P \cup NP$ , define  $\tilde{w} := \tilde{w}_0w_1 = a^kw_1$  (or  $\tilde{w} := w_1\tilde{w}_0 = w_1a^k$ , respectively). Then  $\tilde{w} \in N \cup P \cup NP$ , and the subword  $w_1$  is geodesic.

**Lemma 3.2.** *If  $w$  is a word in  $NP$ ,  $NPX$  or  $XNP$ , and  $\tilde{w}$  contains a subword of the form  $t^{-1}a^{2i}t$  with  $i \in \mathbb{Z}$ , then  $w$  is not geodesic.*

*Proof.* The word  $w$  can be written as  $w = w_0w_1w_2$  with  $w_1 \in NP$  and each of  $w_0$  and  $w_2$  either in  $X$  or  $E$ . Since  $\tilde{w} = \tilde{w}_0w_1\tilde{w}_2$  contains the subword  $t^{-1}a^{2i}t \in NP$ , the word  $t^{-1}a^{2i}t$  must be a subword of  $w_1$ , and hence also of  $w$ . Since  $t^{-1}a^{2i}t =_G a^i$ , this subword is not geodesic, and hence  $w$  also is not geodesic.  $\square$

**Lemma 3.3.** *If  $w$  is any word in  $NP$  or  $NPN$  and  $w =_G 1$ , then  $w$  must contain a subword of the form  $t^{-1}a^{2i}t$  for some  $i \in \mathbb{Z}$ .*

*Proof.* Since  $G = BS(1,2)$  is an HNN extension, Britton's Lemma states that if  $w \in NP(N)$  and  $w =_G 1$ , then  $w$  must contain a subword of the form  $ta^i t^{-1}$  or  $t^{-1}a^{2i}t$  for some  $i \in \mathbb{Z}$ . If  $w \in NP$  then  $w$  must contain the second type of subword.

If  $w \in NPN$ , then  $w = w_1w_2w_3$  with  $w_1, w_3 \in N$  and  $w_2 \in P$ . Since  $\sigma_t(w_1) < 0$  and  $0 = \sigma_t(1) = \sigma_t(w_1) + \sigma_t(w_2) + \sigma_t(w_3)$ ,  $\sigma_t(w_2) > \sigma_t(w_3)$  and the word  $w_2w_3 \in PX$ . Then  $w_2w_3 = w_4w_5$  with  $w_4 \in P$  and  $w_5 \in X$ , and

the word  $w_1w_4\tilde{w}_5 \in NP$  with  $w_1w_4\tilde{w}_5 =_G w =_G 1$ . Then Britton's Lemma applies again to show that the prefix  $w_1w_4$  of  $w$  must contain a subword of the form  $t^{-1}a^{2i}t$  for  $i \in \mathbb{Z}$ .  $\square$

**Lemma 3.4.** *If  $w$  and  $u$  are geodesics,  $w \in NP \cup XNP \cup NPX$ ,  $\sigma_t(w) \leq \sigma_t(u)$ , and  $1 \leq d(\bar{w}, \bar{u}) \leq 2$ , then  $u \in NP \cup XNP \cup NPX$  and for some  $w_1, u_1 \in N$  and  $w_2, u_2 \in P$  with  $\sigma_t(w_1) = \sigma_t(u_1)$ ,  $\tilde{w} = w_1w_2$  and  $\tilde{u} = u_1u_2$ .*

*Proof.* The definition of  $\tilde{w}$  shows that we can write  $\tilde{w} = w_1w_2$  with  $w_1 \in N$  and  $w_2 \in P$ . Let  $\gamma$  label a path of length 1 or 2 from  $\bar{w}$  to  $\bar{u}$ ; since  $\sigma_t(w) \leq \sigma_t(u)$ , then  $\gamma \in E \cup P$ . Proposition 2.3 says that  $\tilde{u} \in E \cup P \cup N \cup NP$ . Since  $w$  is a geodesic, Lemma 3.2 implies that  $\tilde{w}$  cannot contain a subword of the form  $t^{-1}a^{2i}t$  for any integer  $i$ . Then Lemma 3.3 says that the word  $\tilde{w}\gamma\tilde{u}^{-1}$ , which represents the trivial element 1 in  $G$ , cannot be in  $NP(N)$ . Therefore  $\tilde{u} \notin E \cup P \cup N$ , so  $\tilde{u} \in NP$ . Hence  $u \in NP \cup XNP \cup NPX$ .

We can now write  $\tilde{u} = u_1u_2$  with  $u_1 \in N$  and  $u_2 \in P$ . The word  $\tilde{u}^{-1}\tilde{w}\gamma = u_2^{-1}u_1^{-1}w_1w_2\gamma$  is another representative of 1. Repeatedly reducing subwords  $ta^jt^{-1}$  to  $t^{2j}$  in the subword  $\widetilde{u_1^{-1}w_1} \in PN$  results in a word  $\widetilde{u_1^{-1}w_1} \in E \cup P \cup N$ . Then  $1 =_G u_2^{-1}\widetilde{u_1^{-1}w_1}w_2\gamma \in NP(N)$ , so this word must contain a subword of the form  $t^{-1}a^{2i}t$  for some integer  $i$ . Since  $w$  and  $u$  are geodesics,  $w_1w_2$  and  $u_2^{-1}u_1^{-1}$  cannot contain such a subword. Therefore we must have  $\widetilde{u_1^{-1}w_1} \in E$ . Hence  $\sigma_t(w_1) = \sigma_t(u_1)$ .  $\square$

We split the proof of Theorem 3.5 into 10 cases, depending on the classes from Proposition 2.3 to which the two geodesics  $w$  and  $u$  belong. In overview, we begin by showing that the first three cases cannot occur; that is, for a pair of length  $r$  geodesics  $w$  and  $u$  in the respective classes in these three cases, it is not possible for  $d(\bar{w}, \bar{u})$  to be less than three. In cases 4-6, we show that a path  $\delta$  can be found that travels from  $\bar{w}$  along the path  $w^{-1}$  to within a distance 2 of the identity vertex, and, after possibly traversing an intermediate edge,  $\delta$  then travels along a suffix of  $u$  to  $\bar{u}$ . In case 7 we show that the path  $\delta$  can be chosen to have length at most six, traveling around at most two bricks in the Cayley complex. In case 8 there are subcases in which each of the two descriptions above occur, as well as a subcase in which the path  $\delta$  initially follows the inverse of a suffix of  $w$  from  $\bar{w}$ , then travels along a path that "fellow-travels" this initial subpath, and then repeats this procedure by traversing a fellow-traveler of a suffix of  $u$ , and then traveling along the suffix itself to  $\bar{u}$ . In cases 9 and 10, the paths  $\delta$  constructed in each of the subcases follow one of these three patterns.

**Theorem 3.5.** *The group  $G = BS(1, 2) = \langle a, t \mid tat^{-1} = a^2 \rangle$  is  $M'AC$  with respect to the generating set  $A = \{a, a^{-1}, t, t^{-1}\}$ . In particular, if  $w$  and  $u$  are geodesics of length  $r > 200$  with  $1 \leq d(\bar{w}, \bar{u}) \leq 2$ , then there is a path  $\delta$  inside  $B(r)$  from  $\bar{w}$  to  $\bar{u}$  of length at most  $2r - 2$ .*

*Proof.* Suppose that  $w$  and  $u$  are geodesics of length  $r > 200$  with  $1 \leq d(\bar{w}, \bar{u}) \leq 2$ . Using Proposition 2.3, by replacing  $w$  and  $u$  by  $\hat{w}$  and  $\hat{u}$

respectively, we may assume that each of  $w$  and  $u$  are in one of the normal forms listed in that Proposition. Using Lemma 3.1, we may assume that neither  $w$  nor  $u$  is in  $E$ .

Let  $\gamma$  be the word labeling a geodesic path of length at most 2 from  $\bar{w}$  to  $\bar{u}$ , so that  $w\gamma u^{-1} =_G 1$ . Since  $d(\bar{w}, \bar{u}) \geq 1$ ,

$$\gamma \in \{a^{\pm 1}, t^{\pm 1}, a^{\pm 2}, at^{\pm 1}, a^{-1}t^{\pm 1}, ta^{\pm 1}, t^{-1}a^{\pm 1}, t^{\pm 2}\}.$$

Then  $\gamma$  is in one of the sets  $E$ ,  $P$ , or  $N$ .

We divide the argument into ten cases, depending on the class of the normal forms  $w$  and  $u$  from Proposition 2.3, which we summarize in the following table.

Case	Class of $w$	Class of $u$	Case	Class of $w$	Class of $u$
Case 1:	(4)	(1)	Case 6:	(3)	(3)
Case 2:	(4)	(3)	Case 7:	(2)	(2)
Case 3:	(2)	(3)	Case 8:	(1)	(3)
Case 4:	(1)	(1)	Case 9:	(2)	(4)
Case 5:	(1)	(2)	Case 10:	(4)	(4)

This table represents a complete list of the cases to be checked. In particular, if  $w$  is in class (2) and  $u$  in class (1), then the inverse of the path in Case 5 will provide the necessary path  $\delta$ , and similarly for the remainder of the cases.

*Case 1: If  $w$  is in class (4) and  $u$  is in class (1):* Then  $w$  is in either  $NP$ ,  $NPX$  or  $XNP$ , and  $u \in X$ . Since  $\tilde{w} \in NP$ ,  $\tilde{u} \in E$ , and the path  $\gamma$  is either in  $E$ ,  $N$  or  $P$ , then  $1 =_G w\gamma u^{-1} =_G \tilde{w}\gamma\tilde{u}^{-1} \in NP(N)$  (that is, replacing the  $X$  subwords of  $w$  and  $u$  by powers of  $a$ ). By Lemma 3.3,  $\tilde{w}\gamma\tilde{u}^{-1}$  contains a subword of the form  $t^{-1}a^{2s}t \in NP$ , which therefore must occur within  $\tilde{w}$ . Then Lemma 3.2 says that  $w$  is not a geodesic, which is a contradiction. Hence Case 1 cannot hold.

*Case 2: If  $w$  is in class (4) and  $u$  is in class (3):* Then  $w$  is in either  $NP$ ,  $XNP$  or  $NPX$ , and  $u \in P(X)$ . In this case  $1 =_G \tilde{w}\gamma\tilde{u}^{-1} \in NPN$ , and the same proof as in Case 1 shows that Case 2 cannot occur.

*Case 3: If  $w$  is in class (2) and  $u$  is in class (3):* Then  $w \in (X)N$  and  $u \in P(X)$ . Since  $\sigma_t(w) < 0$  and  $\sigma_t(u) > 0$  then we must have  $\sigma_t(w) = -1$ ,  $\sigma_t(u) = 1$ , and  $\gamma = t^2$ . Lemma 3.1 says that  $w \in XN$ , and  $u \in PX$ . Since  $w$  is in normal form,  $w = \hat{w} = w_0 t^{-1} a^i$  with  $|i| \leq 1$  and  $w_0 \in X$ , and similarly  $u = a^j t u_0$  with  $|j| \leq 1$  and  $u_0 \in X$ . Then  $1 =_G \tilde{w}\gamma\tilde{u}^{-1} =_G \tilde{w}_0 t^{-1} a^i t^2 \tilde{u}_0^{-1} t^{-1} a^{-j} \in NPN$ . Lemma 3.3 then says that  $w_0 t^{-1} a^i t^2 \tilde{u}_0^{-1} t^{-1} a^{-j}$  contains a subword of the form  $t^{-1} a^{2s} t$  for some  $s \in \mathbb{Z}$ , so  $i$  must be a multiple of 2, and hence  $i = 0$ . Using the last part of Proposition 2.3, we can further write the normal form for  $w_0 \in X$  as  $w_0 = w_1 t^{-1}$ ,

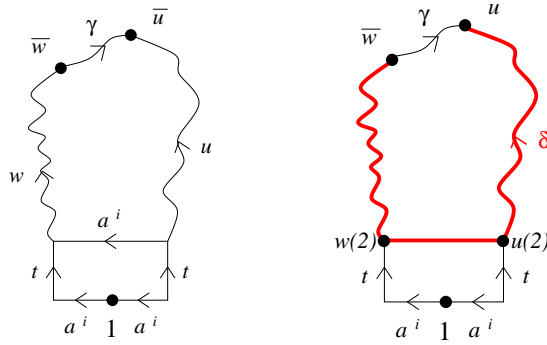
FIGURE 2. Case 6:  $w = a^i t w_1 w_0$ ,  $u = a^{-i} t u_1 u_0$ .

so  $w = w_i t^{-2}$ . Then  $u =_G w \gamma =_G w(r-2)$ , contradicting the hypothesis that  $u$  is a geodesic word of length  $r$ . Thus Case 3 does not hold.

*Case 4: If both  $w$  and  $u$  are in class (1):* Then  $w$  and  $u$  are both in  $X$ . From Proposition 2.3 the normal forms  $w = \hat{w}$  and  $u = \hat{u}$  can be chosen of the form  $\hat{w} = t^h w_1$  and  $\hat{u} = t^i u_1$  with  $h, i > 0$  and  $w_1, u_1 \in N$ . Then  $w$  and  $u$  have a common prefix  $t = w(1) = u(1)$ , and the path  $\delta := w_1^{-1} t^{-(h-1)} t^{i-1} u_1$  from  $\bar{w}$  through  $\overline{w(1)}$  to  $\bar{u}$  has length  $2r - 2$  and stays inside  $B(r)$ .

*Case 5: If  $w$  is in class (1) and  $u$  is in class (2):* Then  $w \in X$  and  $u \in (X)N$ . In this case  $\sigma_t(w) = 0$ ,  $\sigma_t(\gamma) = \sigma_t(w^{-1}u) = \sigma_t(w) + \sigma_t(u) = \sigma_t(u)$ , and  $\sigma_t(u) < 0$ , so  $\sigma_t(u)$  is either  $-1$  or  $-2$ . The hypothesis that  $r > 200$  and Lemma 3.1 imply that  $u \in XN$ . Then both of the normal forms  $\hat{w}$  and  $\hat{u}$  can be chosen to begin with  $t$ , and the same proof as in Case 4 gives the path  $\delta$ .

*Case 6: If both  $w$  and  $u$  are in class (3):* In this case both  $w$  and  $u$  are in  $P(X)$ . Without loss of generality assume that  $\sigma_t(w) \leq \sigma_t(u)$ , so  $\sigma_t(\gamma) \geq 0$  and  $\gamma \in E \cup P$ . Since both  $w$  and  $u$  are in normal form,  $w = a^i t w_1 w_0$  and  $u = a^j t u_1 u_0$  with  $w_1, u_1 \in P \cup E$ ;  $w_0, u_0 \in X \cup E$ ; and  $|i|, |j| \leq 1$ . Then  $1 =_G u^{-1} w \gamma =_G \tilde{u}_0^{-1} u_1^{-1} t^{-1} a^{i-j} t w_1 \tilde{w}_0 \gamma \in NP$ . By Lemma 3.3,  $u_0^{-1} u_1^{-1} t^{-1} a^{i-j} t w_1 \tilde{w}_0 \gamma$  has a subword of the form  $t^{-1} a^{2s} t$ , so  $i-j$  is a multiple of 2 and hence either  $i = j$  with  $0 \leq |i| \leq 1$  or  $i = -j$  with  $|i| = 1$ .

If  $i = j$  then  $w$  and  $u$  have a common prefix  $a^i t = w(1 + |i|) = u(1 + |i|)$ . The path  $\delta := w_0^{-1} w_1^{-1} u_1 u_0$  from  $\bar{w}$  follows the suffix  $w_1 w_0$  of  $w$  backward to  $\overline{w(1 + |i|)}$  and then follows the suffix  $u_1 u_0$  of  $u$  to  $\bar{u}$ , remaining in  $B(r)$ .

If  $i = -j$  with  $|i| = 1$ , define the path

$$\delta := w_0^{-1} w_1^{-1} a^{-i} u_1 u_0 =_G w_0^{-1} w_1^{-1} t^{-1} a^{-i} a^{-i} t u_1 u_0 = w^{-1} u =_G \gamma.$$

Then  $\delta$  labels a path of length  $2r - 3$ , traveling along  $w^{-1}$  from  $\bar{w}$  to  $\overline{w\delta(r-2)} = \overline{w(2)}$ , then along a single edge to  $\overline{w\delta(r-1)} = \overline{u(2)}$ , and finally along a suffix of  $u$  to  $\bar{u}$ , thus remaining in  $B(r)$ . (See Figure 2.)

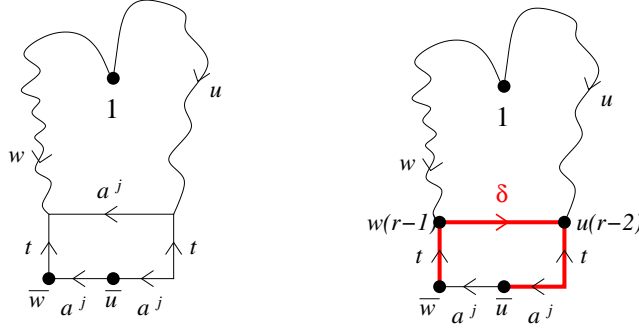

FIGURE 3. Case 7.3:  $w = w_0w_1t^{-1}$ ,  $u = u_0u_1t^{-1}a^j$ .

*Case 7:* If both  $w$  and  $u$  are in class (2): In this case, both  $w$  and  $u$  are in  $(X)N$ . We can assume without loss of generality that  $\sigma_t(w) \leq \sigma_t(u)$ , so again  $\sigma_t(\gamma) \geq 0$  and  $\gamma \in E \cup P$ .

From Proposition 2.3 we have  $w = w_0w_1t^{-1}a^i$  and  $u = u_0u_1t^{-1}a^j$  with  $w_0, u_0 \in X \cup E$ ;  $w_1, u_1 \in N \cup E$ ; and  $|i|, |j| \leq 1$ . Thus  $1 =_G \tilde{w}\gamma\tilde{u}^{-1} = \tilde{w}_0w_1t^{-1}a^i\gamma a^{-j}t u_1^{-1}\tilde{u}_0^{-1} \in NP$ . By Lemma 3.3 the latter contains a subword of the form  $t^{-1}a^{2s}t$ , and so  $t^{-1}a^i\gamma a^{-j}t$  must contain this subword.

Since  $\gamma \in E \cup P$ , then  $\gamma \in \{t, t^2, ta^{\pm 1}, a^{\pm 1}t, a^{\pm 1}, a^{\pm 2}\}$ , and we may divide the argument into four subcases.

*Case 7.1:* If  $\gamma \in \{t, a^{\pm 1}t\}$ : Then  $t^{-1}a^{2s}t$  must be a subword of  $t^{-1}a^i\gamma$ . If  $\gamma = t$ , then since  $|i| \leq 1$  we have  $i = 0$  and  $w = w_0w_1t^{-1}$ , so  $u =_G w\gamma =_G w(r-1)$ . If  $\gamma = a^{\pm 1}t$ , then  $|i| = 1$ , and  $\gamma = a^{\pm i}t$ . If  $\gamma = a^i t$ , then  $u =_G w\gamma = w(r-2)t^{-1}a^i a^i t =_G w(r-2)a_i$ . Finally, if  $\gamma = a^{-i}t$ , then  $u =_G w\gamma = w(r-2)t^{-1}a^i a^{-i}t =_G w(r-2)$ . All three of these options result in a contradiction of the fact that  $u$  is a geodesic of length  $r$ , so subcase 7.1 can't occur.

*Case 7.2:* If  $\gamma \in \{t^2, ta^{\pm 1}\}$ : In this subcase,  $t^{-1}a^{2s}t$  must be a subword of  $t^{-1}a^i t$  again, so  $i = 0$  and  $w = w_0w_1t^{-1}$ . Note that  $\gamma(1) = t$  and  $w\gamma(1) =_G w(r-1)$ . Then  $\gamma$  is a path of length 2 inside  $B(r)$  from  $w$  to  $u$ . In this subcase, we may define the path  $\delta := \gamma$ .

*Case 7.3:* If  $\gamma \in \{a^{\pm 1}\}$ : Write  $\gamma = a^k$  with  $|k| = 1$ . Recall that  $0 \leq |i| \leq 1$ . If  $i = 0$ , then  $t^{-1}a^{2s}t$  must be a subword of  $t^{-1}a^k a^{-j}t$ , so  $2|(k-j)|$  and  $|j| = 1$ . Then  $\gamma = a^{\pm j}$ . If  $\gamma = a^j$ , then  $w =_G u\gamma^{-1} = u(r-2)t^{-1}a^j a^{-j} =_G u(r-2)t^{-1}$ , contradicting the length  $r$  of the geodesic  $w$ . Thus  $\gamma = a^{-j}$ . The word  $\delta := ta^{-j}t^{-1}a^j =_G a^{-j}$  labels a path from  $\bar{w}$  to  $\bar{u}$  of length 4. Since  $w\delta(1) =_G w(r-1)$  and  $w\delta(2) =_G u(r-2)$ , the path  $\delta$  stays inside  $B(r)$ , and hence satisfies the required properties. (See Figure 3.)

If  $|i| = 1$ , then we can write  $\gamma = a^{\pm i}$ . If  $\gamma = a^{-i}$ , then  $u =_G w\gamma =_G w(r-1)$ , again giving a contradiction; hence  $\gamma = a^i$ . Note that the word

$t^{-1}a^{2s}t$  must be a subword of  $t^{-1}a^{2i}a^{-j}t$ , so  $2|(2i - j)$  and  $j = 0$ . Defining  $\delta := a^{-i}ta^i t^{-1} =_G a^i$ , then  $\delta$  labels a path of length 4 from  $\bar{w}$  to  $\bar{u}$ , with  $w\delta(2) =_G w(r - 2)$  and  $w\delta(3) =_G u(r - 1)$ , so the path remains in  $B(r)$  as required.

*Case 7.4: If  $\gamma \in \{a^{\pm 2}\}$ :* Write  $\gamma = a^{2k}$  with  $|k| = 1$ . As in the previous subcase, we consider the options  $i = 0$  and  $|i| = 1$  in separate paragraphs.

If  $i = 0$ , then  $t^{-1}a^{2s}t$  must be a subword of  $t^{-1}a^{2k}a^{-j}t$ , so  $j = 0$ . Then the length 3 path labeled by  $\delta := ta^k t^{-1}$  from  $\bar{w}$  to  $\bar{u}$  traverses the vertices represented by  $w\delta(1) =_G w(r - 1)$  and  $w\delta(2) =_G u(r - 1)$ , hence remaining in  $B(r)$ .

If  $|i| = 1$ , then  $\gamma = a^{\pm 2i}$ . If  $\gamma = a^{-2i}$ , then  $w\gamma(1) =_G w(r - 1)$ , so we may define  $\delta := \gamma$ .

If  $|i| = 1$  and  $\gamma = a^{2i}$ , then  $t^{-1}a^{2s}t$  must be a subword of  $t^{-1}a^{3i}a^{-j}t$ . Thus  $|j| = 1$ , so  $j = \pm i$ . If  $j = i$ , then  $w\gamma(1) =_G u(r - 1)$ , so again the path  $\delta := \gamma$  has the required properties. If  $j = -i$ , then the path of length 6 labeled by  $\delta := a^{-i}ta^{2i}t^{-1}a^{-i} =_G a^{2i}$  starting at  $\bar{w}$  ends at  $\bar{u}$ . Since  $w\delta(2) =_G w(r - 2)$  and  $w\delta(4) =_G u(r - 2)$ , this path also remains within  $B(r)$ .

*Case 8: If  $w$  is in class (1) and  $u$  is in class (3):* Then  $w \in X$  and  $u \in P(X)$ . In this case,  $\sigma_t(w) = 0$ ,  $\sigma_t(u) > 0$ , and  $\sigma_t(u) = \sigma_t(w) + \sigma_t(\gamma) = \sigma_t(\gamma)$ , so  $0 < \sigma_t(u) = \sigma_t(\gamma) \leq 2$ . Thus  $\gamma \in P$ , so  $\gamma \in \{t, ta^{\pm 1}, t^2, a^{\pm 1}t\}$ .

Suppose  $\gamma \in \{t, ta^{\pm 1}, t^2\}$ . By Proposition 2.3 and Lemma 3.1, the normal form  $w$  can be chosen in the form  $w = w_1 t^{-h}$  with  $w_1 \in P$  and  $h > 10$ . Then the length  $r$  geodesic  $u$  cannot represent  $wt =_G w(r - 1)$  or  $wt^2 =_G w(r - 2)$ , so  $\gamma \neq t$  and  $\gamma \neq t^2$ . For  $\gamma = ta^{\pm 1}$ , since  $w\gamma(1) =_G w(r - 1)$ , we may define  $\delta := \gamma$ .

Suppose for the rest of Case 8 that  $\gamma = a^{\pm 1}t$  and write  $\gamma = a^m t$  with  $|m| = 1$ . Proposition 2.3 says that the normal form  $w$  can also be chosen in the form  $w = tw_0 t^{-1} a^i$  with  $w_0 \in X$  and  $0 \leq |i| \leq 1$ . If  $i = m$ , then  $u =_G w\gamma = tw_0 t^{-1} a^m a^m t =_G w(r - 2)a^m$ , and if  $i = -m$ , then  $u =_G tw_0 t^{-1} a^{-m} a^m t = w(r - 2)$ , both contradicting the geodesic length  $r$  of  $u$ . Then  $i = 0$  and  $w = tw_0 t^{-1}$  with  $w_0$  in  $X$ . We also have  $\sigma_t(u) = \sigma_t(\gamma) = 1$ , and Lemma 3.1 implies that  $u \in PX$ , so the normal form  $u = a^j t u_0$  with  $u_0$  in  $X$  and  $|j| \leq 1$ .

If  $j = 0$  then  $w$  and  $u$  have a common  $t$  prefix, and the path  $\delta := tw_0^{-1} u_0$  has the required properties.

Suppose for the remainder of Case 8 that  $|j| = 1$ . Then either  $\gamma = a^j t$  or  $\gamma = a^{-j} t$ ; we consider these two subcases separately.

*Case 8.1: If  $\gamma = a^j t$ :* Applying Lemma 2.1 to commute the subwords in parentheses with zero  $t$ -exponent-sum,  $1 =_G w\gamma u^{-1} = tw_0 t^{-1} (a^j) (t u_0^{-1} t^{-1}) a^{-j} =_G tw_0 u_0^{-1} t^{-1}$ , which yields  $w_0 =_G u_0$ . By Proposition 2.3 we can replace each subword with a normal form  $w_0 = u_0 = vta^k t^{-p}$  such that  $2 \leq |k| \leq 3$  and

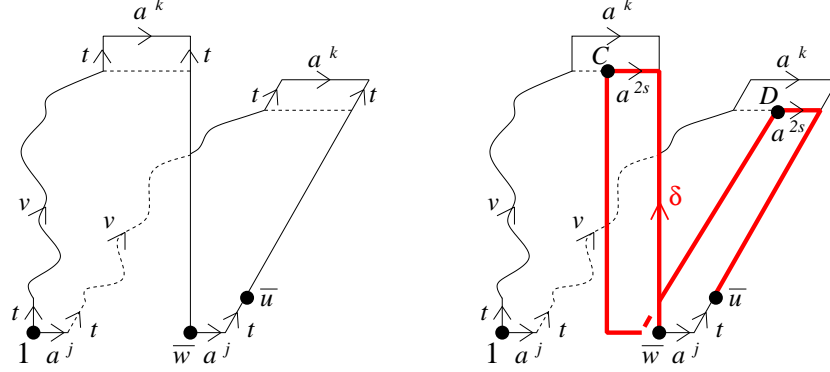

FIGURE 4. Case 8.1:  $w = tvta^k t^{-p-1}$ ,  $u = a^j tvta^k t^{-p}$ ,  $\gamma = a^j t$ .

$v \in P$  with  $\sigma_t(v) = p - 1$ . Since  $r > 200$ , Lemma 3.1 implies that  $p > 10$ . Let  $s := \text{sign}(k)$ . Then  $w = tvta^{|k|s}t^{-(p+1)}$  and  $u = a^j tvta^{|k|s}t^{-p}$ .

Consider the path  $\delta := t^p a^{-2s} t^{-p} a^j t^p a^{2s} t^{1-p}$  starting at  $\bar{w}$ . Using Lemma 2.1,

$$\delta = (t^p a^{-2s} t^{-p})(a^j) t^p a^{2s} t^{-(p-1)} =_G (a^j)(t^p a^{-2s} t^{-p}) t^p a^{2s} t^{-(p-1)} =_G a^j t = \gamma,$$

so  $\delta$  labels a path from  $\bar{w}$  to  $\bar{u}$ . This path  $\delta$  both follows and ‘‘fellow travels’’ suffixes of  $w$  and  $u$ ; see Figure 4 for a view of this path, shown in shading, when  $k$  and  $j$  have the same sign.

In order to check that  $\delta$  remains in the ball  $B(r)$ , we analyze the distances from 1 of several vertices along the path  $\delta$ , and together with the lengths of the subpaths between the vertices. The prefix  $t^p$  of  $\delta$  is the inverse of a suffix of  $w$ , so starting from  $\bar{w}$  the path  $\delta$  follows the path  $w$  backward. Then  $d(1, \overline{w\delta(i)}) = r - i$  for  $0 \leq i \leq p$  and  $w\delta(p) =_G w(r - p)$ . The point  $\overline{w\delta(p+1)}$  must then also lie in the ball  $B(r - (p - 1))$ . Since  $w\delta(p+2) = wt^p a^{-2s} =_G w(r - p) a^{-2s} =_G w(r - p) t a^{-s} t^{-1} =_G w(r - (p+2)) t^{-1}$ , the point  $C := \overline{w\delta(p+2)}$  must lie in the ball  $B(r - (p+1))$ . Then the initial segment of  $\delta$  of length  $p+2$  from  $\bar{w}$  to  $C$  lies inside  $B(r)$ .

Similarly, the suffix  $t^{-(p-1)}$  of  $\delta$  is also a suffix of  $u$ , so  $d(1, \overline{w\delta(3p+5+i)}) = r - (p-1) + i$  for  $0 \leq i \leq p-1$  and  $w\delta(3p+5) =_G u(r - (p-1))$ . The point  $\overline{w\delta(3p+4)} \in B(r - (p-2))$ . Since  $w\delta(3p+3) =_G w\delta(3p+5) a^{-2s} =_G u(r - (p-1)) t a^{-s} t^{-1} =_G a^j tvta^{|k|s} t^{-1} t a^{-s} t^{-1} =_G u(r - (p+1)) t^{-1}$ , the point  $D := \overline{w\delta(3p+3)}$  must lie in the ball  $B(r - p)$ . So the final segment of  $\delta$  of length  $p+1$  from  $D$  to  $\bar{u}$  also lies in  $B(r)$ .

Finally, the central section labeled  $t^{-p} a^j t^p$  of the path  $\delta$  from  $C \in B(r - (p+1))$  to  $D \in B(r - p)$  has length  $2p+1$ , and hence never leaves the ball  $B(r)$ . The entire path  $\delta$  has length  $4p+4$ , whereas  $r = l(v) + |k| + p + 3 \geq (p-1) + 2 + p + 3 = 2p+4$ , so  $l(\delta) \leq 2r - 4$ . Thus the path  $\delta$  has the required properties in this subcase.

*Case 8.2: If  $\gamma = a^{-j}t$ :* Applying Lemma 2.1 again yields  $1 =_G w\gamma u^{-1} = tw_0t^{-1}(a^{-j})(tu_0^{-1}t^{-1})a^{-j} =_G tw_0t^{-1}tu_0^{-1}t^{-1}a^{-j}a^{-j} =_G tw_0u_0^{-1}a^{-j}t^{-1}$ , implying that  $u_0 =_G a^{-j}w_0$ . Plugging this into the expression for  $u$  gives  $u = a^jtu_0 =_G a^jta^{-j}w_0 =_G a^{-j}tw_0$ . Note that  $r = l(w) = l(w_0) + 2$ , so  $a^{-j}tw_0$  is another geodesic from 1 to  $\bar{u}$ . Replacing  $u$  with  $a^{-j}tw_0$ , we can now find the path  $\delta$  using subcase 8.1.

*Case 9: If  $w$  is in class (2) and  $u$  is in class (4):* Then  $w \in (X)N$  and  $u$  is either in  $NP$ ,  $XNP$ , or  $NPX$ . Since  $w \notin (X)NP \cup NPX$ , Lemma 3.4 says that  $\sigma_t(w) < \sigma_t(u)$ . Therefore  $\sigma_t(\gamma) > 0$ , so  $\gamma \in \{t, t^2, a^{\pm 1}t, ta^{\pm 1}\}$ . We divide this case into two subcases, depending on the  $t$ -exponent sum of  $u$ .

*Case 9.1: If  $\sigma_t(u) \leq 0$ :* By Proposition 2.3, the geodesic normal form  $u = u_0u_1t^{-1}a^{m_e}t^f$  with  $u_0 \in X \cup E$ ,  $u_1 \in N$ ,  $|m_e| = 1$ , and  $1 \leq f \leq e = |\sigma_t(u_1)| + 1$ .

*Case 9.1.1: If  $\gamma \in \{t, t^2, a^{\pm 1}t\}$ :* Then  $\gamma$  and  $u$  share a suffix  $t$ , so  $u(r-1) = u\gamma^{-1}(1)$ . The geodesic  $w \neq u(r-1)$ , so  $\gamma \neq t$ . For  $\gamma \in \{t^2, a^{\pm 1}t\}$ , the path  $\delta := \gamma$  has the required properties.

*Case 9.1.2: If  $\gamma \in \{ta^{\pm 1}\}$ :* Write  $\gamma = ta^k$  with  $|k| = 1$ . Also write  $w = w_0w_1$  with  $w_0 \in X \cup E$  and  $w_1 \in N$ . Then

$$\begin{aligned} 1 &=_G \tilde{u}\gamma^{-1}\tilde{w}^{-1} = \tilde{u}_0u_1t^{-1}a^{m_e}t^fa^{-k}t^{-1}w_1^{-1}\tilde{w}_0^{-1} \\ &=_G \tilde{u}_0u_1t^{-1}a^{m_e}t^{f-1}a^{-2k}w_1^{-1}\tilde{w}_0^{-1} \in NP. \end{aligned}$$

Lemma 3.3 implies that the latter word must contain a non-geodesic  $t^{-1}a^{2st}$  subword. Then the first occurrence of a  $t$  must be in  $w_1^{-1}$ , so  $f = 1$ . Write  $u = u_0u_1t^{-1}a^{m_e}t = u_0u'_1t$  with  $u'_1 := u_1t^{-1}a^{m_e} \in N$ . Note that  $w =_G u\gamma^{-1} =_G u_0u'_1ta^{-k}t^{-1} =_G u(r-1)a^{-2k}$ . Let  $v := u_0u'_1a^{-k} = u(r-1)a^{-k} =_G ua^k$ . The vertex  $\bar{v} \in B(r)$ . If  $\bar{v} \in B(r-1)$ , then the path  $\delta := a^{2k}t$  from  $\bar{w}$  to  $\bar{u}$  satisfies  $w\delta(1) =_G v$  and  $w\delta(2) =_G u(r-1)$ , so  $\delta$  is a path of length 3 inside  $B(r)$  from  $\bar{w}$  to  $\bar{u}$ . On the other hand, if  $\bar{v} \notin B(r-1)$ , then  $v$  is a length  $r$  geodesic in  $(X)N$ , and  $w =_G va^{-k}$  so  $d(\bar{v}, \bar{u}) = 1$ . Applying case 7.3 to the geodesics  $v$  and  $w$  in class (2), there is a path  $\delta'$  of length 4 inside  $B(r)$  from  $\bar{w}$  to  $\bar{v}$ . Let  $\delta := \delta'a^k$ . Then  $\delta$  is a path of length 6 from  $\bar{w}$  to  $\bar{u}$  inside  $B(r)$ .

*Case 9.2: If  $\sigma_t(u) > 0$ :* Since  $\sigma_t(w) < 0$  and  $\sigma_t(w) + \sigma_t(\gamma) = \sigma_t(u)$  then we must have  $\sigma_t(w) = -1$ ,  $\sigma_t(u) = 1$ , and  $\gamma = t^2$ . By Proposition 2.3 and Lemma 3.1,  $w = w_0t^{-1}a^i$  with  $w_0 \in X$ ,  $|i| \leq 1$ ,  $w_0 = vta^kt^{-p-1}$  with  $v \in P$ ,  $\sigma_t(v) = p > 9$ , and  $2 \leq |k| \leq 3$ . Since  $u =_G w\gamma = vta^kt^{-p}t^{-2}a^it^2$  and  $u$  has geodesic length  $r = l(w) = l(v) + |k| + |i| + p + 3$ , then  $i \neq 0$ . Using Lemma 2.1,  $u =_G (t^{-1}a^it)(vta^kt^{-p-1})t$ . The word  $x := t^{-1}a^itvta^kt^{-p}$  is another geodesic labeling a path from the identity to  $\bar{u}$ .

Let  $s := \text{sign}(k)$ , and define the path

$$\delta := a^{-i}t^{p+1}a^{-2s}t^{-(p-1)}t^{-2}a^it^2t^{p-1}a^{2s}t^{-(p-1)}$$

starting at  $\bar{w}$ . Using Lemma 2.1,

$$\delta =_G a^{-i}t^{p+1}a^{-2s}t^{-(p-1)}(t^{p-1}a^{2s}t^{-(p-1)})(t^{-2}a^i t^2) =_G t^2 = \gamma,$$

so  $\delta$  labels a path from  $\bar{w}$  to  $\bar{u} = \bar{x}$ . The length  $l(\delta) = 4p + 8$ , and the length  $r = l(w) = l(v) + |k| + p + 4 \geq 2p + 6$ , so  $l(\delta) \leq 2r - 4$ .

The proof that  $\delta$  remains in  $B(r)$  is similar to case 8.1. In particular, note that  $\overline{w\delta(p+2)} = \overline{w(r-(p+2))} \in B(r-(p+2))$ . Since  $w\delta(p+4) = \overline{(vta^k t^{-p} t^{-2} a^i)(a^{-i} t^{p+1} a^{-2s})} =_G \overline{vta^{k-s} t^{-1}} =_G \overline{w(r-(p+4))t^{-1}}$ , the point  $\overline{w\delta(p+4)} \in B(r-(p+3))$ . Also  $\overline{w\delta(3p+9)} = \overline{x(r-(p-1))} \in B(r-(p-1))$ . Finally, since  $w\delta(3p+7) =_G \overline{x(r-(p-1))a^{-2s}} =_G \overline{t^{-1}a^i t v t a^k t^{-1} a^{-2s}} =_G \overline{t^{-1}a^i t v t a^k t^{-1}} =_G \overline{x(r-(p+1))t^{-1}}$ , then the point  $\overline{w\delta(3p+7)} \in B(r-p)$ . Then the five successive intermediate subpaths of  $\delta$  between  $\bar{w}$ , these four points, and  $\bar{u}$  are too short to allow  $\delta$  to leave  $B(r)$ .

*Case 10:* If both  $w$  and  $u$  are in class (4): In this case both  $w$  and  $u$  are in  $(X)NP \cup NPX$ . We may assume without loss of generality that  $\sigma_t(w) \leq \sigma_t(u)$ . It follows that  $\sigma_t(\gamma) \geq 0$ , so  $\gamma \in \{a^{\pm 1}, a^{\pm 2}, a^{\pm 1}t, ta^{\pm 1}, t, t^2\}$ .

We divide this case into three subcases, depending on the  $t$ -exponents of  $w$  and  $u$ .

*Case 10.1:* If  $\sigma_t(w) \geq 0$  and  $\sigma_t(u) \geq 0$ : In this case Proposition 2.3 says that we have geodesic normal forms  $u, w \in NP(X)$ , and moreover  $w = t^{-p_1}w'$  and  $u = t^{-p_2}u'$  with  $p_1 > 0$ ,  $p_2 > 0$ , and  $w', u' \in P(X)$ . Thus  $w(1) = t^{-1} = u(1)$ , and we may define  $\delta := w'^{-1}t^{p_1-1}t^{-(p_2-1)}u'$ .

*Case 10.2:* If  $\sigma_t(w) < 0$  and  $\sigma_t(u) \leq 0$ : In this subcase, we have normal forms  $w, u \in (X)NP$ , and we can write

$$w = w_0 w_1 t^{-1} a^{i_1} t^{f_1} \quad \text{and} \quad u = u_0 u_1 t^{-1} a^{i_2} t^{f_2}$$

with  $w_0, u_0 \in X \cup E$ ,  $w_1 \in N$ ,  $u_1 \in N \cup E$ ,  $f_1 \geq 1$ ,  $f_2 \geq 1$ ,  $\sigma_t(w_1) \leq -f_1$ ,  $\sigma_t(u_1) \leq -(f_2 - 1)$ , and  $|i_1| = |i_2| = 1$ . Lemma 3.4 implies that  $\sigma_t(w_1) = \sigma_t(u_1)$ . Then  $\sigma_t(w\gamma) = \sigma_t(w_1) - 1 + f_1 + \sigma_t(\gamma) = \sigma_t(u) = \sigma_t(u_1) - 1 + f_2$ , so  $f_2 = f_1 + \sigma_t(\gamma) \geq f_1$ .

*Case 10.2.1:* If  $\gamma \in \{t, t^2, a^{\pm 1}t\}$ : Since the last letter of  $u$  is  $t$ , the proof of Case 9.1.1 shows that  $\gamma \neq t$ , and for  $\gamma \in \{t^2, a^{\pm 1}t\}$ , we may define  $\delta := \gamma$ .

*Case 10.2.2:* If  $\gamma \in \{a^{\pm 1}\}$ : Write  $\gamma = a^k$  with  $|k|=1$ . The word  $\delta := t^{-1}a^{2k}t$  labels a path of length 4 from  $\bar{w}$  to  $\bar{u}$ . Since both words  $w$  and  $u$  end with a  $t$ , then  $w\delta(1) =_G w(r_1)$  and  $w\delta(3) =_G u(r-1)$ , hence  $\delta$  lies in  $B(r)$ .

*Case 10.2.3:* If  $\gamma \in \{ta^{\pm 1}\}$ : Write  $\gamma = ta^k$  with  $|k| = 1$ . In this subcase,  $f_2 = f_1 + \sigma_t(\gamma) = f_1 + 1 \geq 2$ . Then the word  $w$  ends with a  $t$  and  $u$  ends with  $t^2$ . Now  $u = u(r-1)t =_G w\gamma = wta^k =_G wa^{2k}t$ . Let  $v := u(r-1)a^{-k} =_G wa^k$ . Then  $v \in (X)NP$  and  $\bar{v} \in B(r)$ . The remainder of the proof in this subcase is similar to Case 9.1.2. If  $v \in B(r-1)$ , then  $\delta := a^{2k}t$  has the required properties. If  $v \notin B(r-1)$ , then Case 10.2.2 provides a path

$\delta' = t^{-1}a^{2k}t$  inside  $B(r)$  from  $\bar{w}$  to  $\bar{v}$ , and the path  $\delta := \delta'a^k t = t^{-1}a^{2k}ta^k t$  from  $\bar{w}$  to  $\bar{u}$  satisfies the required conditions.

*Case 10.2.4:* If  $\gamma \in \{a^{\pm 2}\}$ : Write  $\gamma = a^{2k}$  with  $|k| = 1$ . In this case we have  $\sigma_t(u) = \sigma_t(w) < 0$  and  $f_2 = f_1 + \sigma_t(\gamma) = f_1$ .

The radius  $r = l(w) = l(w_0) + l(w_1) + 2 + f_1 \geq \sigma_t(w_1) + 2 + f_1 \geq 2f_1 + 2$ . If  $r = 2f_1 + 2$ , then  $w = t^{-f_1-1}a^{i_1}t^{f_1}$  and  $u = t^{-f_1-1}a^{i_2}t^{f_1}$ . Since  $\bar{w} \neq \bar{u}$ , then  $i_1 \neq i_2$ , so  $i_2 = -i_1$ . Since  $r > 200$ , then  $f_1 > 1$ . Now  $u^{-1}w\gamma =_G (t^{-f_1-1}a^{i_2}t^{f_1})^{-1}(t^{-f_1-1}a^{i_1}t^{f_1})a^{2k} =_G t^{-(f_1-1)}a^{i_1}t^{f_1-1}a^{2k}$ ; according to Britton's Lemma, this last expression cannot equal the trivial element 1 in  $G$ . Thus the radius  $r \neq 2f_1 + 2$ , so  $r \geq 2f_1 + 3$ .

Define  $\delta := t^{-f_1}(a^{-i_1})(t^{f_1}a^{2k}t^{-f_1})a^{i_1}t^{f_1}$ . Using Lemma 2.1 to commute the subwords in parentheses, and freely reducing the resulting word, shows that  $\delta =_G a^{2k} = \gamma$ , so  $\delta$  labels a path from  $\bar{w}$  to  $\bar{u}$ . The length  $l(\gamma) = 4f_1 + 4 = 2(2f_1 + 3) - 2 \leq 2r - 2$ . The prefix  $\delta(f_1 + 2) = w^{-1}(f_1 + 2)$  is the inverse of a suffix of  $w$ , so  $\overline{w\delta(f_1 + 2)} = \overline{w(r - (f_1 + 2))} \in B(r - (f_1 + 2))$ . The word  $t^{f_1}$  is a suffix of both  $\delta$  and  $u$ , so  $\overline{w\delta(3f_1 + 4)} = \overline{u(r - f_1)} \in B(r - f_1)$ . The three subpaths of  $\delta$  between  $\bar{w}$ , the two points above, and  $\bar{u}$  are again too short to allow  $\delta$  to leave  $B(r)$ .

*Case 10.3:* If  $\sigma_t(w) < 0$  and  $\sigma_t(u) > 0$ : Then  $\gamma = t^2$ ,  $\sigma_t(w) = -1$ , and  $\sigma_t(u) = 1$ . From Proposition 2.3, the normal form  $w = w_0t^{-1}a^{m_1}t^{-1} \dots t^{-1}a^{m_p}t^{p-1}$  with either  $w_0 \in X$  or  $w_0 = a^k \in E$  for some  $|k| \leq 3$ ,  $p \geq 2$ , and  $|m_p| = 1$ . Using Lemma 2.1, then the word  $\check{w} := w_0t^{-p}a^{m_p}ta^{m_{p-1}} \dots ta^{m_1}$  is another geodesic representative of  $\bar{w}$ . The normal form for  $u \in NP(X)$  has the form  $u = t^{-e}a^jtu_1u_0$  with  $e \geq 1$ ,  $|j| = 1$ ,  $u_1 \in P$  with  $\sigma_t(u_1) = p$ , and  $u_0 \in X \cup E$ . Lemma 3.4 shows that  $p = e$ . Replacing  $w$  by the alternate normal form  $\check{w}$ , then we can write

$$w = w_0t^{-p}a^i tw_2 \quad \text{and} \quad u = t^{-p}a^j tu_1 u_0$$

such that either  $w_0 \in X$  or  $w_0 = a^k$  for  $|k| \leq 3$ ,  $p \geq 2$ ,  $|i| = 1$ ,  $w_2 \in P \cup E$  with  $\sigma_t(w_2) = p - 2$ ,  $|j| = 1$ ,  $u_1 \in P$  with  $\sigma_t(u_1) = p$ , and  $u_0 \in X \cup E$ .

We will divide case 10.3 into further subcases, depending on the form of  $w_0$  and the length of  $w_2$ .

*Case 10.3.1:* If  $w_0 \in X$ : In this case Proposition 2.3 says that we can write  $w_0 = w_3ta^k t^{-l}$  with  $l \geq 1$ ,  $w_3 \in P \cup E$ ,  $\sigma_t(w_3) = l - 1$ , and  $2 \leq |m| \leq 3$ . Let  $s = \pm 1$  be the sign of  $m$ , so that  $m = |m|s$ . Then

$$w = w_3ta^{|m|s}t^{-l}t^{-p}a^i tw_2 .$$

The radius  $r = l(w_3) + l(w_2) + |m| + l + p + 3 \geq \sigma_t(w_3) + l(w_2) + l + p + 5 = l(w_2) + 2l + p + 4$ .

Applying Lemma 2.1, we obtain  $u =_G \check{w}t^2 = (w_3ta^{|m|s}t^{-l})(t^{-p}a^i tw_2 t)t =_G t^{-p}a^i tw_2 tw_3 ta^{|m|s}t^{-(l-1)}$ . Then

$$\check{u} := t^{-p}a^i tw_2 tw_3 ta^{|m|s}t^{-(l-1)} .$$

is another geodesic representative of  $\bar{u}$ .

*Case 10.3.1.1: If  $l \geq 2$ :* Define

$$\delta := (w_2^{-1}t^{-1}a^{-i}t^{p-1})(t^l a^{-2m}t^{-l})t^{-(p-1)}a^i t w_2 t^l a^{2m}t^{-(l-2)}.$$

Applying Lemma 2.1 to the subwords in parentheses shows that  $\delta =_G t^2 = \gamma$ , so  $\delta$  labels a path from  $\bar{w}$  to  $\bar{u} = \bar{u}$ . The length  $l(\delta) = 2l(w_2) + 4l + 2p + 4 \leq 2r - 4$ .

The vertex  $\overline{w\delta(l(w_2) + p + l + 1)} = \overline{w(r - (l(w_2) + p + l + 1))} \in B(r - (l(w_2) + p + l + 1))$ . Now  $w\delta(l(w_2) + p + l + 3) \stackrel{=}{=} w_3 t a^{|m|s} t^{-1} a^{-2s} \stackrel{=}{=} w_3 t a^{(|m|-1)s} t^{-1} w(r - (l(w_2) + p + l + 3)) t^{-1}$ , implying  $\overline{w\delta(l(w_2) + p + l + 3)} \in B(r - (l(w_2) + p + l + 2))$ . The suffix  $t^{-(l-2)}$  of  $\delta$  is also a suffix of  $\check{u}$ , so  $\overline{w\delta(2l(w_2) + 3l + 2p + 6)} = \overline{\check{u}(r - (l - 2))} \in B(r - (l - 2))$ . Finally,  $w\delta(2l(w_2) + 3l + 2p + 4) \stackrel{=}{=} \check{u}(r - (l - 2)) a^{-2s} \stackrel{=}{=} t^{-p} a^i t w_2 t w_3 t a^{|m|s} t^{-1} a^{-2s} \stackrel{=}{=} t^{-p} a^i t w_2 t w_3 t a^{(|m|-1)s} t^{-1}$ , so  $\overline{w\delta(2l(w_2) + 3l + 2p + 4)} = \overline{\check{u}(r - l)} t^{-1} \in B(r - (l - 1))$ . The five subpaths of  $\delta$  between  $\bar{w}$ , these four points, and  $\bar{u}$  are each too short to leave  $B(r)$ .

*Case 10.3.1.2: If  $l = 1$ :* In this case define

$$\delta := (w_2^{-1}t^{-1}a^{-i}t^{p-1})(t a^{-2s} t^{-1})t^{-(p-1)}a^i t w_2 t^2 a^s.$$

Commuting the subwords in parentheses, then  $\delta =_G t^2 = \gamma$  and  $\delta$  labels a path from  $\bar{w}$  to  $\bar{u}$ . The length  $l(\delta) = 2l(w_2) + 2p + 9 = 2l(w_2) + 4l + 2p + 5 \leq 2r - 3$ .

The proof that  $\delta$  remains in  $B(r)$  is similar to Case 10.3.1.1. In particular,  $\overline{w\delta(l(w_2) + p + 2)} = \overline{w(r - (l(w_2) + p + 2))} \in B(r - (r - (l(w_2) + p + 2)))$ ,  $\overline{w\delta(l(w_2) + p + 4)} = \overline{w(r - (l(w_2) + p + 4))} t^{-1} \in B(r - (r - (l(w_2) + p + 3)))$ ,  $\overline{w\delta(2l(w_2) + 2p + 8)} = \overline{\check{u}(r - 1)} \in B(r - 1)$ , and the four successive subpaths between  $\bar{w}$ , these three points, and  $\bar{u}$  are too short for  $\delta$  to leave  $B(r)$ .

*Case 10.3.2: If  $w_0 = a^k$  with  $|k| \leq 3$ , and  $l(w_2) = p - 2$ :* Since  $\sigma_t(w_2) = p - 2$ , then  $w_2 = t^{p-2}$  and  $w = a^k t^{-p} a^i t^{p-1}$  with  $p \geq 2$  and  $|i| = 1$ . Recall that  $u = t^{-p} a^j t u_1 u_0$  with  $|j| = 1$  and  $\sigma_t(u_1) = p$ . The radius  $r = |k| + 2p = p + 2 + l(u_1 u_0)$ , so  $|k| = l(u_1 u_0) - p + 2 \geq 2$ .

If  $|k| = 2$ , then  $l(u_1 u_0) = p$  and  $u = t^{-p} a^j t^{p+1}$ . The trivial element  $1 =_G w t^2 u^{-1} = a^k t^{-p} a^i t^{p-1} t^2 t^{-(p+1)} a^{-j} t^p =_G a^k t^{-p} a^i a^{-j} t^p$ . Since  $a^k \neq_G 1$ ,  $i \neq j$ . But  $a^k t^{-p} a^i a^i t^p =_G a^k t^{-(p-1)} a^i t^{(p-1)}$ , and Britton's Lemma says that the latter word cannot represent the trivial element 1, so  $i \neq -j$ . Therefore we cannot have  $|k| = 2$ .

If  $|k| = 3$ , then  $l(u_1 u_0) = p + 1$  and  $\sigma_t(u_1) = p$ , so the word  $u_1 u_0$  contains one occurrence of  $a$  or  $a^{-1}$ . Write  $u_1 u_0 = t^b a^l t^{p-b}$  for some  $0 \leq b \leq p$  and  $|l| = 1$ . Then  $w t^2 u^{-1}$  freely reduces to  $a^k t^{-p} a^i t (t^b a^{-l} t^{-b}) (a^{-j}) t^p$ . Commuting the parenthetical subwords and reducing again gives  $1 =_G w t^2 u^{-1} =_G a^k t^{-p} a^i t a^{-j} t^b a^{-l} t^{p-b}$ . This word is in  $NP$ , and doesn't contain a subword

of the form  $t^{-1}a^{2m}t$ , so Britton's Lemma (or Lemma 3.3) implies a contradiction again. Therefore case 10.3.2 cannot occur.

*Case 10.3.3:* If  $w_0 = a^k$  with  $|k| \leq 3$  and  $l(w_2) \geq p-1$ : In this case we have the geodesic normal forms  $w = a^k t^{-p} a^i t w_2$  and  $u = t^{-p} a^j t u_1 u_0$ . The radius  $r = l(w_2) + |k| + p + 2 = l(u_1 u_0) + p + 2$ . We have two subcases, depending on whether  $i = j$  or  $i \neq j$ .

*Case 10.3.3.1:* If  $i = j$ : In this subcase note that  $\gamma = t^2 =_G w^{-1}u = w_2^{-1} t^{-1} (a^{-j}) (t^p a^{-k} t^{-p}) a^j t u_1 u_0$ . Applying Lemma 2.1 and reducing shows that the word  $\delta := w_2^{-1} t^{p-1} a^{-k} t^{-(p-1)} u_1 u_0 =_G \gamma$ , and so  $\delta$  labels a path from  $\bar{w}$  to  $\bar{u}$ . The length  $l(\delta) = 2r - 6$ .

As usual we analyze the distances from 1 of several vertices along the path  $\delta$ .  $\overline{w\delta(l(w_2))} = \overline{w(r-l(w_2))} \in B(r-l(w_2))$ ,  $\overline{w\delta(l(w_2)+2p-2+|k|)} = \overline{u(r-l(u_1 u_0))} \in B(r-l(u_1 u_0))$ , and the three intervening subpaths are each too short to allow  $\delta$  to leave  $B(r)$ .

*Case 10.3.3.2:* If  $i = -j$ : Similar to Case 10.3.3.1, after commuting and reduction we have  $\gamma =_G w^{-1}u =_G w_2^{-1} t^{p-1} a^{-k} t^{-p} a^j t u_1 u_0$ . Then the word  $\delta := w_2^{-1} t^{p-1} w_0^{-1} t^{-(p-1)} a^j u_1 u_0 =_G \gamma$  labels a path from  $\bar{w}$  to  $\bar{u}$  and has length  $l(\delta) = 2r - 5$ .

As in Case 10.3.3.1, we have  $\overline{w\delta(l(w_2))} = \overline{w(r-l(w_2))} \in B(r-l(w_2))$  and  $\overline{w\delta(l(w_2)+2p-1+|k|)} = \overline{u(r-l(u_1 u_0))} \in B(r-l(u_1 u_0))$ . Now  $\overline{w\delta(l(w_2)+2p-2+|k|)} =_G (t^{-p} a^j t) a^{-j} =_G t^{-p} a^{-j} t$ , so  $\overline{w\delta(l(w_2)+2p-2+|k|)} = \overline{u(r-(l(u_1 u_0)+2)) a^{-j} t} \in B(r-l(u_1 u_0))$  as well. The four successive subpaths of  $\delta$  between  $\bar{w}$ , these three vertices, and  $\bar{u}$  have lengths too short to allow  $\delta$  to leave  $B(r)$ . Therefore  $\delta$  has the required properties.

Therefore in all of cases 1-10, either the case cannot occur or the path  $\delta$  with the required properties can be constructed, completing the proof of Theorem 3.5.  $\square$

#### 4. NON-CONVEXITY PROPERTIES FOR $BS(1, q)$

In the first half of this section we show, in Theorem 4.3, that the group  $G := BS(1, 2) = \langle a, t \mid tat^{-1} = a^2 \rangle$  with generators  $A := \{a, a^{-1}, t, t^{-1}\}$  does not satisfy Poenaru's  $P(2)$  almost convexity condition. We start by defining some notation. Let  $n$  be an arbitrary natural number with  $n > 100$  and let  $w := t^n a^2 t^{-n}$  and  $u := at^n a^2 t^{-(n-1)}$  (see Figure 5). Then  $w$  and  $u$  are words of length  $R := 2n + 2$ . Moreover, using Lemma 2.1,  $wat = (a)(t^n a^2 t^{-n})t =_G u$ , so  $d(\bar{w}, \bar{u}) = 2$  and the word  $\gamma := at$  labels a path from  $\bar{w}$  to  $\bar{u}$ .

**Lemma 4.1.** *If  $m \in \mathbb{Z}$  and  $\bar{a^m}$  is in the ball  $B(R) = B(2n + 2)$  in the Cayley graph of  $G$ , then either  $m = 2^{n+1}$  or  $m \leq 2^n + 2^{n-1} + 2^{n-2}$ .*

*Proof.* For  $\bar{a^m} \in B(R)$ , Proposition 2.3 says that there is a geodesic word  $V$  in the normal form  $v = t^h a^s t^{-1} a^{k_{h-1}} t^{-1} \dots t^{-1} a^{k_0}$  with  $2 \leq |s| \leq 3$  and

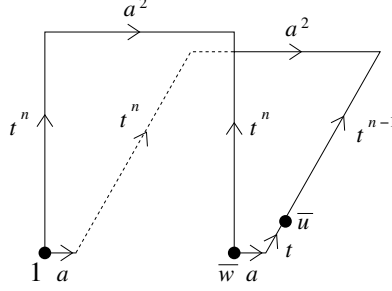

 FIGURE 5.  $w = t^n a^2 t^{-n}$ ,  $u = a t^n a^2 t^{-(n-1)}$ 

each  $|k_i| \leq 1$ , such that  $v =_G a^m$ . This word contains  $2h$  letters of the form  $t^{\pm 1}$  and  $l(v) \leq 2n + 2$ , so  $h \leq n$ . Also,  $v =_G a^{2^h s + 2^{h-1} k_{h-1} + \dots + k_0} =_G a^m$ , so  $m = 2^h s + 2^{h-1} k_{h-1} + \dots + k_0$ .

If  $h = n$ , then  $v = t^n a^{\pm 2} t^{-n}$ , so  $m = \pm 2^{n+1}$ . If  $h = n - 1$ , then there are at most 4 occurrences of  $a^{\pm 1}$  in the expression for  $v$ ; that is,  $|s| + \sum |k_i| \leq 4$ . The value of  $m$  will be maximized if  $s = +3$ ,  $k_{h-1} = +1$ , and  $k_i = 0$  for all  $i \leq h - 2$ ; in this case,  $m = (3)2^{n-1} + 2^{n-2} = 2^n + 2^{n-1} + 2^{n-2}$ .

Finally, if  $h \leq n - 2$ , then  $m \leq 2^{n-2}(3) + 2^{n-3}(1) + \dots + (1) = \frac{2^n - 1}{2 - 1}$ , so  $m < 2^n + 2^{n-1} + 2^{n-2}$ .  $\square$

**Lemma 4.2.** *The words  $w = t^n a^2 t^{-n}$ ,  $wa$ ,  $wa^{-1}$ ,  $wt^{-1}$ , and  $u = a t^n a^2 t^{-(n-1)}$  label geodesics in the Cayley graph of  $G$ .*

*Proof.* As a consequence of Lemma 4.1, the vertices  $\overline{a^{2^{n+1}+1}}$  and  $\overline{a^{2^{n+1}-1}}$  are not in the ball  $B(R)$ . The words  $t^n a^2 t^{-n} a = wa$  and  $aw$  both label paths from the identity to  $\overline{a^{2^{n+1}+1}}$ , and the word  $wa^{-1}$  labels a path from 1 to  $\overline{a^{2^{n+1}-1}}$ . Each of these words has length  $2n + 3 = R + 1$ , so all three paths must be geodesic. As a consequence, the subwords  $w$  of  $wa$  and  $u$  of  $aw$  are also geodesic.

The element  $\overline{wt^{-1}}$  has a geodesic normal form from Proposition 2.3 given by  $v = t^h a^s t^{-1} a^{k_{h-1}} t^{-1} \dots t^{-1} a^{k_0} t^{-1} a^l$  with  $|l| \leq 1$ . Since  $a^{2^{n+1}} t^{-1} v^{-1} =_G 1$ , Lemma 3.3 shows that  $a^l = a^{2^i}$  with  $i \in \mathbb{Z}$ , so  $l = 0$ . Hence  $\overline{wt^{-1}}$  is also geodesic.  $\square$

**Theorem 4.3.** *The group  $G = BS(1, 2) = \langle a, t \mid tat^{-1} = a^2 \rangle$  is not  $P(2)$  with respect to the generating set  $A = \{a, a^{-1}, t, t^{-1}\}$ .*

*Proof.* Let  $n \in \mathbb{N}$  with  $n > 100$ ,  $w = t^n a^2 t^{-n}$ ,  $u = a t^n a^2 t^{-(n-1)}$ , and  $R = 2n + 2$ . Then  $\overline{w}$  and  $\overline{u}$  lie in the sphere  $S(R)$  and  $d(\overline{w}, \overline{u}) = 2$ . Let  $\delta$  be a path inside the ball  $B(R)$  from  $\overline{w}$  to  $\overline{u}$  that has minimal possible length. In particular,  $\delta$  does not have any subpaths that traverse a single vertex more than once.

From Lemma 4.2,  $\overline{wa^{\pm 1}}$  and  $\overline{wt^{-1}}$  are not in  $B(R)$ , so the first letter of the path  $\delta$  must be  $t$ . Let  $\pi : \mathcal{C} \rightarrow T$  denote the horizontal projection map from

the Cayley complex of  $G$  to the regular tree  $T$  of valence 3, as described at the beginning of Section 2. The vertices  $\pi(\overline{w\delta(1)}) = \pi(\overline{t})$  and  $\pi(\overline{u}) = \pi(\overline{at})$  are the terminal vertices of the two distinct edges of  $T$  with initial vertex  $\pi(\overline{w}) = \pi(1)$ . Since the projection of the path  $\delta$  begins at  $\pi(1)$ , goes to  $\pi(\overline{t})$ , and eventually ends at  $\pi(\overline{at})$ , there must be another point  $P := \overline{w\delta(j)}$  along the path  $\delta$  with  $\pi(P) = \pi(\overline{w\delta(j)}) = \pi(1)$  and  $1 < j < l(\delta)$ . Let  $\delta_1$  be the subpath of  $\delta$  from  $\overline{w}$  to  $P$ .

Our assumption that  $\delta$  has minimal possible length implies that  $P \neq \overline{w}$ . Since  $\pi(P) = \pi(1)$ ,  $P =_G a^m$  for some  $m \in \mathbb{Z}$ . Then Lemma 4.1 shows that  $m \leq 2^n + 2^{n-1} + 2^{n-2}$ . Since  $\delta_1$  labels a path from  $\overline{a^{2^{n+1}}}$  to  $\overline{a^m}$ , then  $\delta_1^{-1} =_G a^{2^{n+1}-m} = a^k$  with  $k = 2^{n+1} - m \geq 2^{n-2} > 2^{(n-4)+1}$ . Applying the contrapositive of Lemma 4.1,  $\overline{a^k}$  is not in the ball  $B(2(n-4) + 2)$ , so the length  $l(\delta_1^{-1}) > 2(n-4) + 2$ . Therefore  $l(\delta) > R - 8$ , so this length cannot be bounded above by a sublinear function of  $R$ .  $\square$

For the remainder of this section, let  $G_q := BS(1, q) = \langle a, t \mid tat^{-1} = a^q \rangle$  with  $q \geq 7$  and with generators  $A := \{a, a^{-1}, t, t^{-1}\}$ . We will apply methods very similar to those developed above, to show that these groups are not MAC.

**Lemma 4.4.** *If  $m \in \mathbb{Z}$  and  $\overline{a^m}$  is in the ball  $B(R) = B(2n + 1)$  in the Cayley graph of  $G_q$ , then either  $m = q^n$  or  $m \leq 3q^{n-1}$ .*

*Proof.* For  $\overline{a^m} \in B(R)$ , Proposition 2.3 says that there is a geodesic word  $V$  in the normal form  $v = t^h a^s t^{-1} a^{k_{h-1}} t^{-1} \dots t^{-1} a^{k_0}$  with  $1 \leq |s| \leq q - 1$  and each  $|k_i| \leq \lfloor \frac{q}{2} \rfloor$ , such that  $v =_G a^m$ . Then  $h \leq n$  and  $m = q^h s + q^{h-1} k_{h-1} + \dots + k_0$ .

If  $h = n$ , then  $v = t^n a^{\pm 1} t^{-n}$ , and  $m = \pm q^n$ . If  $h = n - 1$ , then there are at most 3 occurrences of  $a^{\pm 1}$  in the expression for  $v$ . The value of  $m$  will be maximized if  $s = +3$ , in which case,  $m = (3)q^{n-1}$ . Finally, if  $h \leq n - 2$ , then  $m \leq q^{n-2}(q - 1) + q^{n-3} \lfloor \frac{q}{2} \rfloor + \dots + (\lfloor \frac{q}{2} \rfloor) = q^{n-1} - q^{n-2} + \frac{q^{n-2}-1}{2-1} \lfloor \frac{q}{2} \rfloor$ , so  $m < 3q^{n-1}$ .  $\square$

**Theorem 4.5.** *The group  $G_q = BS(1, q) = \langle a, t \mid tat^{-1} = a^q \rangle$  with  $q \geq 7$  is not MAC with respect to the generating set  $A = \{a, a^{-1}, t, t^{-1}\}$ .*

*Proof.* Let  $n$  be an arbitrary natural number with  $n > 100$ . Let  $w' := t^n a t^{-n}$  and  $u' := a t^n a t^{-(n-1)}$ . Then  $w'$  and  $u'$  are words of length  $R := 2n + 1$ . As a consequence of Lemma 4.4, an argument similar to the proof of Lemma 4.2 shows that the words  $w'$ ,  $u'$ ,  $w' a^{\pm 1}$ , and  $w' t^{-1}$  are geodesics. Hence  $\overline{w'}$  and  $\overline{u'}$  lie in  $S(R)$ . Lemma 2.1 says that  $w' a t^{-1} = (a)(t^n a t^{-n}) t^1 =_G u'$ , so  $d(\overline{w'}, \overline{u'}) = 2$  and the word  $\gamma := a t^1$  labels a path from  $\overline{w'}$  to  $\overline{u'}$ . Let  $\delta$  be a path inside the ball  $B(R)$  from  $\overline{w'}$  to  $\overline{u'}$  that has minimal possible length.

Using the information on geodesics from the previous paragraph, the first letter of the path  $\delta$  must be  $t$ . Let  $\pi : \mathcal{C} \rightarrow T$  denote the horizontal projection map from the Cayley complex of  $G_q$  to the regular tree  $T$  of valence  $q + 1$ .

The vertices  $\pi(\overline{w'\delta(1)}) = \pi(\bar{t})$  and  $\pi(\bar{u}') = \pi(\overline{at})$  are the terminal vertices of two distinct edges of  $T$  with initial vertex  $\pi(\bar{w}') = \pi(1)$ . Consequently, there must be a point  $P := \overline{w'\delta(j)}$  along the path  $\delta$  with  $\pi(P) = \pi(\overline{w'\delta(j)}) = \pi(1)$  and  $1 < j < l(\delta)$ . Write  $\delta = \delta_1\delta_2$  where  $\delta_1$  is the subpath of  $\delta$  from  $\bar{w}'$  to  $P$ .

The vertex  $P \neq \bar{w}' = \overline{a^{q^n}}$ , and  $P =_{G_q} a^m$  for some  $m \in \mathbb{Z}$ , so Lemma 4.4 shows that  $m < 3q^{n-1}$ . The word  $\delta_1$  labels a path from  $\overline{a^{q^n}}$  to  $\overline{a^m}$ , so  $\delta_1 =_{G_q} a^k$  with  $k = q^n - m \geq (q-3)q^{n-1} > 3q^{n-1}$  since  $q \geq 7$ . Then Lemma 4.4 says that either  $k = q^n$  or  $\overline{a^k}$  is not in the ball  $B(2n+1)$ .

If  $\overline{a^k}$  is not in the ball  $B(2n+1)$ , then the length  $l(\delta_1) > 2n+1 = R$ . Note that  $u't^{-1} = aw' =_{G_q} a^{q^n+1}$ . The word  $\delta_2t^{-1}$  labels a path from  $P = \overline{a^m}$  to  $\overline{a^{q^n+1}}$ , so  $\delta_2t^{-1} =_{G_q} a^{k+1}$  with  $k+1 > 3q^{n-1}$ . Then the length  $l(\delta_2t^{-1}) > R$  as well. Thus  $l(\delta_2) \geq R$  and the length  $l(\delta) \geq R+1+R = 2R+1$ . Since there is a path  $w'^{-1}u'$  of length  $2R$  inside  $B(R)$  from  $\bar{w}'$  to  $\bar{u}'$ , this contradicts our choice of  $\delta$  with minimal length.

Then the path  $\delta$  satisfies  $k = q^n$ , so  $P = 1$ . Therefore the path  $\delta$  reaches the vertex corresponding to the identity, and the length of the path  $\delta$  is  $2R$ .  $\square$

**Corollary 4.6.** *The properties MAC and M'AC are not commensurability invariant, and hence also not quasi-isometry invariant.*

*Proof.* The index 3 subgroup of  $BS(1,2) = \langle a, t \mid tat^{-1} = a^2 \rangle$  generated by  $a$  and  $t^3$  is isomorphic to  $BS(1,8)$ . Theorem 3.5 shows that  $BS(1,2)$  is M'AC and hence MAC, and Theorem 4.5 proves that  $BS(1,8)$  has neither property.  $\square$

## 5. STALLINGS' GROUP IS NOT MAC

In [15], Stallings showed that the group with finite presentation

$$S := \langle a, b, c, d, s \mid [a, c] = [a, d] = [b, c] = [b, d] = 1, \\ (a^{-1}b)^s = a^{-1}b, (a^{-1}c)^s = a^{-1}c, (a^{-1}d)^s = a^{-1}d \rangle$$

does not have homological type  $FP_3$ . In our notation,  $[a, c] := aca^{-1}c^{-1}$  and  $(a^{-1}b)^s := sa^{-1}bs$ . Let  $X := \{a, b, c, d, s, a^{-1}, b^{-1}, c^{-1}, d^{-1}, s^{-1}\}$  be the inverse closed generating set, and let  $\Gamma$  be the corresponding Cayley graph of  $S$ .

Let  $G$  be the subgroup of  $S$  generated by  $Y := \{a, b, c, d, a^{-1}, b^{-1}, c^{-1}, d^{-1}\}$ , and let  $\Lambda$  be the corresponding Cayley graph of  $G$ . Then  $G$  is the direct product of the nonabelian free groups  $\langle a, b \rangle$  and  $\langle c, d \rangle$ . Let  $H$  be the finitely generated subgroup of  $G$  given by  $H = \langle a^{-1}b, a^{-1}c, a^{-1}d \rangle$ .

**Lemma 5.1.** *The group  $H$  consists of all elements of  $G$  that can be represented by a word over  $Y$  of exponent sum zero. Moreover, every word, over  $X$  or  $Y$ , representing an element of  $H$  must have exponent sum zero.*

*Proof.* Using the fact that  $a$  commutes with both  $c$  and  $d$ , we have that  $ca^{-1}, da^{-1} \in H$ , and so their inverses  $ac^{-1}, ad^{-1} \in H$ . Using the fact that  $b$  and  $c$  commute,

$$\begin{aligned} ab^{-1} &=_S a(c^{-1}c)b^{-1} =_S (ac^{-1})b^{-1}c =_S (ac^{-1})b^{-1}(aa^{-1})c \\ &=_S (ac^{-1})(a^{-1}b)^{-1}(a^{-1}c) \in H \end{aligned}$$

as well. Taking products of the form  $h_1^{-1}h_2$  with

$$h_1, h_2 \in \{a^{-1}b, a^{-1}c, a^{-1}d, ab^{-1}, ac^{-1}, ad^{-1}\}$$

shows that  $l_1^{-1}l_2, l_1l_2^{-1} \in H$  for all positive letters  $l_1, l_2 \in \{a, b, c, d\}$ . Finally, consider an arbitrary word  $w = l_1^{\epsilon_1} \cdots l_n^{\epsilon_n}$  with  $l_i \in \{a, b, c, d\}$ ,  $\epsilon_i = \pm 1$ , and  $\sum_i \epsilon_i = 0$ . For each  $i$ , there is a letter  $m \in Y$  which commutes with both  $l_i^{\epsilon_i}$  and  $l_{i+1}^{\epsilon_{i+1}}$ . Repeating the technique above of inserting the inverse pair  $mm^{-1}$  between  $l_i^{\epsilon_i}$  and  $l_{i+1}^{\epsilon_{i+1}}$  and applying the commutation relations as needed, then  $w$  can be written as a product of elements of exponent sum zero of the form  $m_1m_2$  with  $m_i \in Y$ . Then  $\bar{w} \in H$ . The second sentence of this lemma follows from the fact that the exponent sum for each of generators of  $H$  and each of the relators in the presentation for  $S$  is zero.  $\square$

Let  $\phi : H \rightarrow H$  be the identity function. Then  $S$  is the HNN extension  $S = G \star_\phi$  with stable letter  $s$ , and  $s$  commutes with all of the elements of  $H$ .

**Lemma 5.2.** *Let  $w \in X^*$ .*

- (1) *If  $w$  is a geodesic in  $\Gamma$ , then the word  $w$  cannot contain a subword of the form  $sus^{-1}$  or  $s^{-1}us$  with  $\bar{u} \in H$ .*
- (2) *If  $\bar{w} \in G$  and  $w$  is a geodesic in  $\Gamma$ , then  $w \in Y^*$  and  $w$  is a geodesic in  $\Lambda$ .*
- (3) *If  $w \in Y^*$  and  $w$  is a geodesic in  $\Lambda$ , then  $w, sw$  and  $ws$  are all geodesics in  $\Gamma$ .*

*Proof.* Part (1) follows directly from the fact that for  $\bar{u} \in H$ ,  $sus^{-1} =_S s^{-1}us =_S u$ . In parts (2) and (3), suppose that  $g \in G$ ,  $v$  is a geodesic word over  $X$  in  $\Gamma$  representing  $g$ , and  $w \in Y^*$  is a geodesic in  $\Lambda$  with  $\bar{w} = g$  also. Then  $vw^{-1} =_S 1$ . Britton's Lemma applied to the HNN extension  $S$  says that if either  $s$  or  $s^{-1}$  occurs in  $vw^{-1}$ , then  $vw^{-1}$ , and hence  $v$ , must contain a subword of the form  $sus^{-1}$  or  $s^{-1}us$  with  $\bar{u} \in H$ , contradicting part (1). Therefore  $v \in Y^*$ . Since  $v, w \in Y^*$  and  $v$  is a geodesic in  $\Lambda$ , then  $l(v) \leq l(w)$ . Similarly since  $v, w \in X^*$  and  $w$  is a geodesic in  $\Gamma$ ,  $l(w) \leq l(v)$ . Thus  $v$  is also a geodesic in  $\Lambda$ , and  $w$  is a geodesic in  $\Gamma$ .

For the remainder of part (3), suppose that  $\mu$  is a geodesic representative of  $sw$  in  $\Gamma$ . Then  $w^{-1}s^{-1}\mu =_S 1$ . Britton's Lemma then says that  $w^{-1}s^{-1}\mu$  must contain a subword of the form  $sus^{-1}$  or  $s^{-1}us$  with  $\bar{u} \in H$ . Since  $\mu$  is a geodesic, part (1) says that the  $sus^{-1}$  or  $s^{-1}us$  cannot be completely contained in  $\mu$ , so we can write  $\mu = \mu_1s\mu_2$  with  $\bar{\mu}_1 \in H$ . Since  $\mu_1$  and  $s$  commute,  $s\mu_1\mu_2 =_S \mu =_S sw$ , so  $\mu_1\mu_2 =_S w$  and both  $\mu_1\mu_2$  and  $w$  are

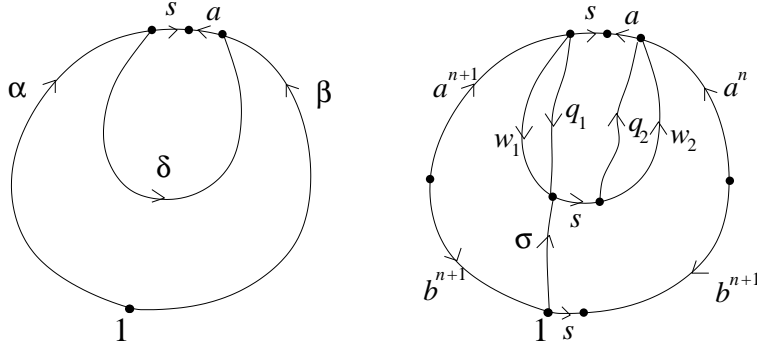

FIGURE 6. Paths in the Cayley graph of Stallings' group.

geodesics representing the same element of  $G$ . Hence  $l(\mu_1\mu_2) = l(w)$ . Then  $l(\mu) = l(\mu_1) + 1 + l(\mu_2) = l(w) + 1 = l(sw)$ , so  $sw$  is a geodesic in  $\Gamma$ . The proof that  $ws$  is also a geodesic in  $\Gamma$  is similar.  $\square$

The proof of the following theorem relies further on the HNN extension structure of Stallings' group  $S$ . In particular, we utilize an “ $s$ -corridor” to show that the path  $\delta$  in the definition of *MAC* cannot exist.

**Theorem 5.3.** *( $S, X$ ) is not MAC with respect to the generating set  $X$ .*

*Proof.* Let  $\alpha := b^{-(n+1)}a^{n+1}$  and  $\beta := sb^{-(n+1)}a^n$ , and let  $\chi = b^{-(n+1)}a^n$  be their maximal common subword. The word  $\alpha \in Y^*$ , so  $\bar{\alpha} \in G$ ; in particular, the exponent sum of  $\alpha$  is zero, so Lemma 5.1 says  $\bar{\alpha} \in H$  also. Since  $\alpha$  is a geodesic in the Cayley graph  $\Lambda$  of the group  $G = F_2 \times F_2$ , Lemma 5.2(3) says that  $\alpha$  is a geodesic in  $\Gamma$ . Similarly,  $\chi$  is a geodesic in  $\Lambda$ , so Lemma 5.2(3) says that  $\beta = s\chi$  is also geodesic in  $\Gamma$ . Thus  $\alpha$  and  $\beta$  lie in the sphere of radius  $2n + 2$  in  $\Gamma$ . Since

$$\alpha^{-1}\beta = a^{-(n+1)}b^{n+1}sb^{-(n+1)}a^n =_S sa^{-(n+1)}b^{n+1}b^{-(n+1)}a^n =_S sa^{-1},$$

the distance  $d(\bar{\alpha}, \bar{\beta}) = 2$ , for all natural numbers  $n$ .

Suppose there is a path  $\delta$  of length at most  $2(2n + 2) - 1$  inside the ball of radius  $2n + 2$  between  $\bar{\alpha}$  and  $\bar{\beta}$ . Since the relators in the presentation of  $S$  have even length, the word  $\delta$  must have length at most  $2(2n + 2) - 2 = 4n + 2$ .

Applying Britton's Lemma to the product  $\delta as^{-1} =_S 1$  implies that  $\delta = w_1sw_2$  with  $\bar{w}_1, \bar{w}_2a \in H$ . Then  $\bar{w}_1, \bar{w}_2 \in G = F_2 \times F_2$ . Lemma 5.2(2) and the direct product structure imply that there are geodesic representatives  $q_1$  and  $q_2$  of  $\bar{w}_1$  and  $\bar{w}_2$ , respectively, that have the form  $q_1 = q_{1,a,b}q_{1,c,d}$  and  $q_2 = q_{2,c,d}q_{2,a,b}$  with  $q_{1,a,b}, q_{2,a,b} \in \{a, b, a^{-1}, b^{-1}\}^*$  and  $q_{1,c,d}, q_{2,c,d} \in \{c, d, c^{-1}, d^{-1}\}^*$ .

Since  $\bar{\alpha}$  and  $\bar{q}_1 = \bar{w}_1$  are both elements of  $H$ ,  $\bar{\alpha}\bar{q}_1 \in H$  as well. From the direct product structure, there is a geodesic representative  $\sigma \in Y^*$  of  $\bar{\alpha}\bar{q}_1$  of the form  $\sigma = \sigma_{a,b}\sigma_{c,d}$  with  $\sigma_{a,b} \in \{a, b, a^{-1}, b^{-1}\}^*$  and  $\sigma_{c,d} \in \{c, d, c^{-1}, d^{-1}\}^*$ . (see Figure 6).

The edge in  $\Gamma$  labeled by  $s$  connecting  $\bar{\sigma}$  and  $\bar{\sigma}s$  is part of the path  $\delta$ , so this edge must lie in the ball of radius  $2n + 2$  in  $\Gamma$ . Lemma 5.2(3) says that

$\sigma s$  is a geodesic, so  $d(1, \bar{\sigma}) + 1 = l(\sigma) + 1 = l(\sigma s) = d(1, \bar{\sigma s}) \leq 2n + 2$ . Then the vertex  $\bar{\sigma} \in B(2n + 1)$  and  $l(\sigma) \leq 2n + 1$ .

Now  $l(q_1) + 1 + l(q_2) \leq l(\delta) \leq 4n + 2$ , and thus either  $l(q_1) \leq 2n$  or  $l(q_2) \leq 2n$  (or both).

*Case A: If  $l(q_1) \leq 2n$ :* Note that  $\alpha q_1 \sigma^{-1} = b^{-(n+1)} a^{n+1} q_{1_{a,b}} q_{1_{c,d}} \sigma_{c,d}^{-1} \sigma_{a,b}^{-1} =_{F_2 \times F_2} 1$ . Hence  $q_{1_{c,d}} =_{F_2} \sigma_{c,d}$  and  $\alpha q_{1_{a,b}} =_{F_2} \sigma_{a,b}$ . Since geodesics in free groups are unique, we also have  $q_{1_{c,d}} = \sigma_{c,d}$ .

There is an integer  $0 \leq i_1 \leq 2n$  such that  $q_{1_{a,b}}(i_1) = \alpha^{-1}(i_1)$  but  $q_{1_{a,b}}(i_1 + 1) \neq \alpha^{-1}(i_1 + 1)$ , where we denote  $q_{1_{a,b}}(0) := 1$  and  $q_{1_{a,b}}(k) := q$  for all  $k > l(q_{1_{a,b}})$ . Write  $q_{1_{a,b}} = \alpha^{-1}(i_1)r$  with  $r \in F_2 = \langle a, b \rangle$ . The words  $\alpha$ ,  $q_{1_{a,b}}$ , and  $\sigma_{a,b}$  are all geodesic representatives of elements of the free group  $F_2$ , and hence these are freely reduced words that define non-backtracking edge paths in the tree given by the Cayley graph for this group. By definition of  $i_1$ , the product  $\alpha q_{1_{a,b}}$  freely reduces to  $\alpha(2n + 2 - i_1)r$ , with no further free reduction possible. Then  $\alpha(2n + 2 - i_1)r$  is the unique geodesic representative in  $F_2 = \langle a, b \rangle$  of  $\alpha q_{1_{a,b}}$ , and hence  $\alpha(2n + 2 - i_1)r = \sigma_{a,b}$ .

*Case A.1: If  $i_1 \leq n + 1$ :* In this case,  $q_{1_{a,b}} = a^{-i_1}r$ . Now  $q_1 = q_{1_{a,b}}q_{1_{c,d}} = a^{-i_1}r q_{1_{c,d}}$  represents an element of  $H$ , and so Lemma 5.1 says  $q_1$  has exponent sum zero. Then  $l(r q_{1_{c,d}}) \geq i_1$ . We also have  $\sigma = \sigma_{a,b} \sigma_{c,d} = \alpha(2n + 2 - i_1)r q_{1_{c,d}}$ . Then the length  $l(\sigma) \geq (2n + 2 - i_1) + i_1 = 2n + 2$ , contradicting the result above that  $l(\sigma) \leq 2n + 1$ . Thus this subcase cannot occur.

*Case A.2: If  $i_1 > n + 1$ :* In this case,  $\sigma_{a,b} = b^{-(2n+2-i_1)}r$ . Since  $\sigma = \sigma_{a,b} \sigma_{c,d} = b^{-(2n+2-i_1)}r \sigma_{c,d}$  represents an element of  $H$ , this word has exponent sum zero, so  $l(r \sigma_{c,d}) \geq 2n + 2 - i_1$  in this subcase. The word  $q_1 = q_{1_{a,b}}q_{1_{c,d}} = \alpha^{-1}(i_1)r \sigma_{c,d}$  then has length  $l(q_1) \geq i_1 + (2n + 2 - i_1) = 2n + 2$ , contradicting the fact that we are in Case A.

*Case B: If  $l(q_2) \leq 2n$ :* Since  $\sigma \in H$ ,  $\sigma$  commutes with  $s$ . Then

$$\sigma =_S s^{-1} \sigma s =_S s^{-1} \alpha q_1 s =_S s^{-1} \alpha q_1 s q_2 q_2^{-1} =_S s^{-1} \beta q_2^{-1} =_S \chi q_2^{-1}.$$

In this case  $\sigma_{a,b} \sigma_{c,d} =_{F_2 \times F_2} b^{-(n+1)} a^{n+1} q_{2_{a,b}}^{-1} q_{2_{c,d}}^{-1}$ , so  $q_{2_{c,d}}^{-1} =_{F_2} \sigma_{c,d}$  and  $\chi q_{2_{a,b}}^{-1} =_{F_2} \sigma_{a,b}$ . Uniqueness of geodesics in  $F_2 = \langle c, d \rangle$  implies  $q_{2_{c,d}}^{-1} = \sigma_{c,d}$ .

There is an integer  $0 \leq i_2 \leq 2n$  such that  $q_{2_{a,b}}^{-1}(i_2) = \chi^{-1}(i_2)$  but  $q_{2_{a,b}}^{-1}(i_2 + 1) \neq \chi^{-1}(i_2 + 1)$ . Write  $q_{2_{a,b}} = r(\chi^{-1}(i_2))^{-1}$  with  $r \in F_2 = \langle a, b \rangle$ . The words  $\chi$ ,  $q_{2_{a,b}}$ , and  $\sigma_{a,b}$  are all geodesics, and hence freely reduced words, in  $F_2$ . By definition of  $i_2$ , the product  $\chi q_{2_{a,b}}^{-1}$  freely reduces to  $\chi(2n + 1 - i_2)r^{-1}$ , with no further reduction possible. Then  $\chi(2n + 1 - i_2)r^{-1} = \sigma_{a,b}$ .

*Case B.1: If  $i_2 \leq n$ :* In this case,  $q_{2_{a,b}} = r a^{i_2}$ . Now  $q_2 = q_{2_{c,d}} q_{2_{a,b}} = q_{2_{c,d}} r a^{i_2}$ . Recall that  $q_2$  was chosen as a geodesic representative of an element

$\overline{w_2} \in G$  for which  $\overline{w_2 a} \in H$ . Then  $q_2 a$  represents an element of  $H$ , and so (by Lemma 5.1) has exponent sum zero. Therefore the exponent sum of  $q_2$  is  $-1$ . Then  $l(q_{2c,d} r) \geq i_2 + 1$ . We also have  $\sigma = \sigma_{a,b} \sigma_{c,d} = \chi(2n + 1 - i_2) r^{-1} q_{2c,d}^{-1}$ . Then the length  $l(\sigma) \geq (2n + 1 - i_2) + (i_2 + 1) = 2n + 2$ , again contradicting the result above that  $l(\sigma) \leq 2n + 1$ .

*Case B.2: If  $i_2 > n$ :* In this case,  $\sigma_{a,b} = b^{-(2n+1-i_2)} r^{-1}$ . Since  $\sigma = \sigma_{a,b} \sigma_{c,d} = b^{-(2n+1-i_2)} r^{-1} \sigma_{c,d}$  represents an element of  $H$ , this word has exponent sum zero, so  $l(r^{-1} \sigma_{c,d}) \geq 2n + 1 - i_2$  in this subcase. Therefore the word  $q_2 = q_{2c,d} q_{2a,b} = \sigma_{c,d}^{-1} r(\chi^{-1}(i_1))^{-1}$  has length  $l(q_2) \geq (2n + 1 - i_2) + i_2 = 2n + 1$ , contradicting the fact that we are in Case B.

Therefore every possible subcase results in a contradiction implying that the subcase cannot occur. Then the path  $\delta$  cannot exist, so  $S$  is not *MAC* with respect to the generating set  $X$ .  $\square$

## REFERENCES

- [1] James Belk and Kai-Uwe Bux. Thompson's Group F is not Minimally Almost Convex. arXiv:math.GR/0301141.
- [2] Martin R. Bridson. Doubles, finiteness properties of groups, and quadratic isoperimetric inequalities. *J. Algebra*, 214(2):652–667, 1999.
- [3] James W. Cannon. Almost convex groups. *Geom. Dedicata*, 22(2):197–210, 1987.
- [4] Murray Elder. Automaticity, almost convexity and falsification by fellow traveler properties of some finitely generated groups. PhD Dissertation, University of Melbourne, 2000.
- [5] Murray Elder. The loop shortening property and almost convexity. *Geom. Dedicata*, 102(1):1–18, 2003.
- [6] David B. A. Epstein, James W. Cannon, Derek F. Holt, Silvio V. F. Levy, Michael S. Paterson, and William P. Thurston. *Word processing in groups*. Jones and Bartlett Publishers, Boston, MA, 1992.
- [7] Louis Funar. On discrete solvgroups and Poénaru's condition. *Arch. Math. (Basel)*, 72(2):81–85, 1999.
- [8] J. R. J. Groves. Minimal length normal forms for some soluble groups. *J. Pure Appl. Algebra*, 114(1):51–58, 1996.
- [9] Victor Guba. The Dehn Function of Richard Thompson's Group F is Quadratic. arXiv:math.GR/0211395.
- [10] Ilya Kapovich. A note on the Poénaru condition. *J. Group Theory*, 5(1):119–127, 2002.
- [11] Charles F. Miller, III. Normal forms for some Baumslag-Solitar groups. Preprint 1997.
- [12] Charles F. Miller, III and Michael Shapiro. Solvable Baumslag-Solitar groups are not almost convex. *Geom. Dedicata*, 72(2):123–127, 1998.
- [13] V. Poénaru. Almost convex groups, Lipschitz combing, and  $\pi_1^\infty$  for universal covering spaces of closed 3-manifolds. *J. Differential Geom.*, 35(1):103–130, 1992.
- [14] Tim R. Riley. The geometry of groups satisfying weak almost-convexity or weak geodesic-combability conditions. *J. Group Theory*, 5(4):513–525, 2002.
- [15] John Stallings. A finitely presented group whose 3-dimensional integral homology is not finitely generated. *Amer. J. Math.*, 85:541–543, 1963.
- [16] Carsten Thiel. *Zur fast-Konvexität einiger nilpotenter Gruppen*. Universität Bonn Mathematisches Institut, Bonn, 1992. Dissertation, Rheinische Friedrich-Wilhelms-Universität Bonn, Bonn, 1991.

SCHOOL OF MATHEMATICS AND STATISTICS, UNIVERSITY OF ST. ANDREWS, NORTH  
HAUGH, ST. ANDREWS, FIFE, KY16 9SS, SCOTLAND

*E-mail address:* `murray@mcs.st-and.ac.uk`

DEPARTMENT OF MATHEMATICS, UNIVERSITY OF NEBRASKA, LINCOLN NE 68588-  
0323, USA

*E-mail address:* `smh@math.unl.edu`